



Puron
the environmentally sound refrigerant

R410A DC Inverter VRF Series 50/60Hz



XPOWER
VRF Series 60 Hz and 50 Hz

Products Lineup

X-Power Full DC Inverter Super S Series

Capacity Range	HP	8	10	12	14	16	18
	kW	25.2	28.0	33.5	40.0	45.0	50.0
	Btu/h	86,000	95,500	114,300	136,500	153,500	170,600
Appearance							

X-Power Full DC Inverter Mini H Series

Capacity Range	HP	3	4	4	5	6	7	8	10	14	16
	KW	8	10.5	12	14	16	20	22.4	26	40	45
	Btu/h	27,300	35,830	40,950	47,770	54,600	68,240	76,430	88,700	136,480	153,540
Appearance											



CONTENTS



»» **03** Overview

»» **08** X-Power Full Inverter Super S Series

»» **20** X-Power Full DC Inverter Mini H Series

»» **32** Indoor Units Lineup

»» **66** Control Systems

»» **91** Branch Pipe



A low-angle, upward-looking photograph of several modern skyscrapers with glass facades. The buildings are reflected in each other, creating a complex geometric pattern of lines and shapes. The sky is visible at the top, and the overall color palette is dominated by blues and greys.

Overview >>

High efficiency DC inverter compressor

Carrier X-Power VRF Air Conditioner achieves the industry's top class energy efficiency of cooling EER and heating COP by utilizing the Brushless Reluctance DC compressor control, improved performance heat exchanger by innovative design and numerous high performance key parts. High efficiency DC inverter compressor reduces power consumption by 25%.



Powerful magnets provide high torque and efficiency and achieve 70% reduction in volume.

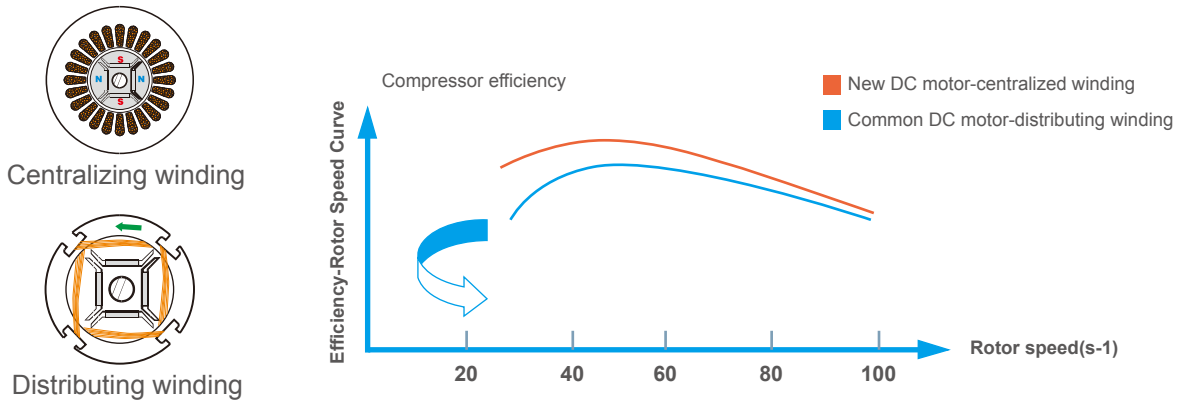

Smooth 180° sine wave DC inverter

Adopting the 180° Sine Wave Inverter to smooth motor rotation greatly improves operating efficiency compared with traditional sawtooth wave.

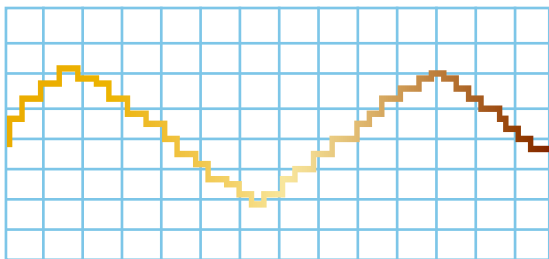

Common Sawtooth Wave

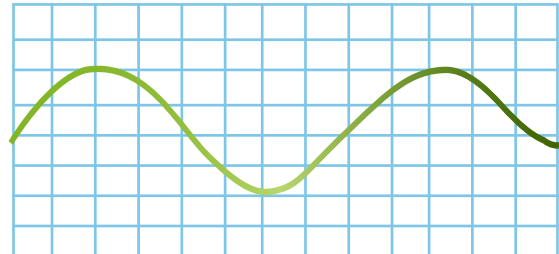

180° Sine Wave DC Inverter

High efficiency DC fan motor

According to the running load and system pressure, the system controls the speed of DC fan to achieve the minimum energy consumption and best performance.



DC motor

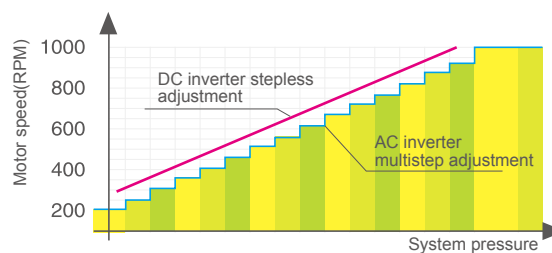

Optimized fan grille

Optimized fan blade shape with new air outlet grille enhanced air flow volume which greatly improves fan performance and decreases noise.

Also, a higher external static pressure has been achieved up to 40Pa. (0-20Pa is standard, 20~40Pa should be customized.)



New profile fan blade

A new blade with sharp edges and a slight curve increases the airflow rate and lowers vibration and airflow resistance.

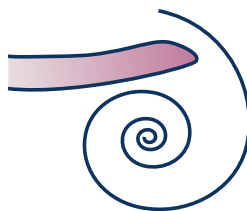
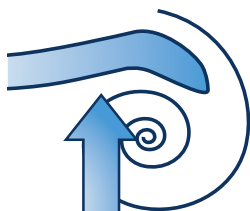

Multi solenoid valves control technology

Multi solenoid valves control technology in one system. All the solenoid valves equipped in the unit ensure temperature-control precisely, system running steadily and economic to provide a comfortable environment.



Cycle duty operation

In one combination, any of the outdoor unit can run as the master unit and master unit can cycle in a period, to realize the equal lifespan among the outdoor units. As a result extend the system lifespan significantly.



Backup operation

In a multiple system, if one module is failed, other modules can be backup instead of the failed one for continuing operation.



Precise oil control technology

5 stage oil control technology ensures every outdoor unit & compressor's oil always keep in the safe level, completely solve the compressor oil lack problem.

1st stage: compressor internal oil separate

2nd stage: high efficiency oil separator (separation efficiency up to 99%)

3rd stage: oil balance technology between compressors

4th stage: oil balance technology between modules

5th stage: intelligent system oil return program

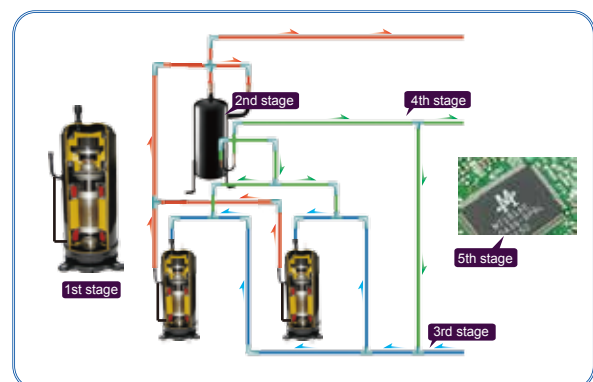

Double EXV control technology

Double EXV Control Technology in one system, each EXV part achieves 480 pulse to adjust flow precisely. Ensure the temperature-control precisely and steadily to provide a comfortable environment.



Intelligent soft start technology

DC inverter compressor soft start function reduces strike to the electric network. This kind of high-performance and low sound scroll compressor operates at a faster rate when starting, reducing start-up time. It also helps the unit to quickly adjust the room temperature to the set level.

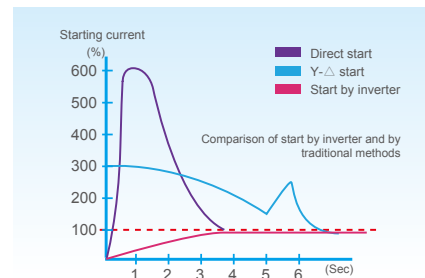

Quick warm-up & cool-down design

By utilizing the benefits of the inverter compressor, the system can reach full load quickly and shorten the warm-up and cool-down times to provide an immediate and comfortable air solution. Less temperature fluctuation will create a better living environment.

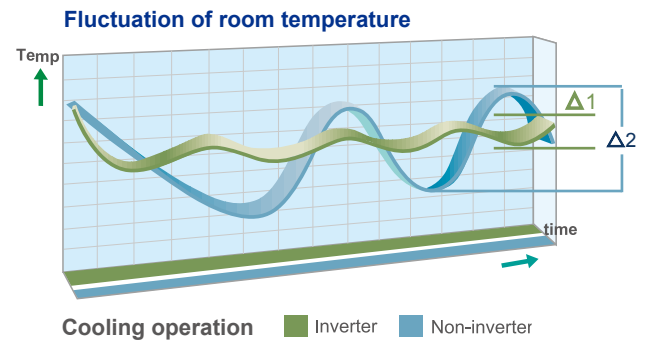

Compact design for effective use of space

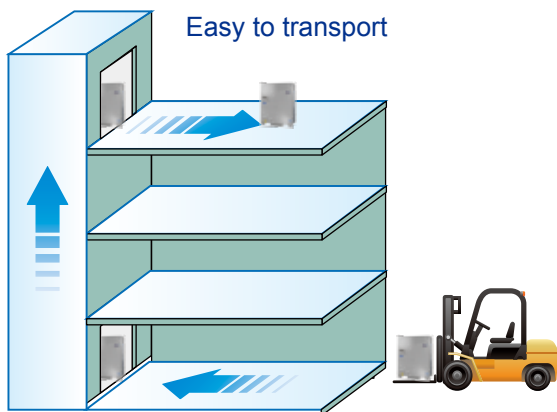

Compact size and light weight design minimizes the installation footprint, reduces the installation floor load, and is easier for transportation. For some projects the units can even be transported through the elevator or forklift, reduce access problem at the jobsite.



X-Power Full Inverter Super S Series >>

Recommended combination table

Model	N° of Outdoor Units	N° of Compressors	Outdoor Unit Combination						Maximum N° of Connectable Indoor Units	Capacity			
			8HP	10HP	12HP	14HP	16HP	*18HP		Cooling		Heating	
										kW	kBtu/h	kW	kBtu/h
8HP	1	1	1						13	25.2	86.0	27.0	92.1
10HP	1	1		1					16	28.0	95.5	31.5	107.5
12HP	1	2			1				20	33.5	114.3	37.5	128.0
14HP	1	2				1			23	40.0	136.5	45.0	153.5
16HP	1	2					1		26	45.0	153.5	50.0	170.6
*18HP	1	2						1	29	50.0	170.6	56.0	191.1
20HP	2	2		2					33	56.0	191.1	63.0	215.0
22HP	2	3		1	1				36	61.5	209.8	69.0	235.4
24HP	2	3		1		1			39	68.0	232.0	76.5	261.0
26HP	2	3		1			1		43	73.0	249.1	81.5	278.1
28HP	2	3		1				1	46	78.0	266.1	87.5	298.6
30HP	2	4				1	1		50	85.0	290.0	95.0	324.1
32HP	2	4				1		1	53	90.0	307.1	101.0	344.6
34HP	2	4					1	1	56	95.0	324.1	106.0	361.7
36HP	2	4						2	59	100.0	341.2	112.0	382.1
38HP	3	4		2				1	63	106.0	361.7	119.0	406.0
40HP	3	5		1		1	1		64	113.0	385.6	126.5	431.6
42HP	3	5				3			64	120.0	409.4	135.0	460.6
44HP	3	5		1			1	1	64	123.0	419.7	137.5	469.2
46HP	3	5		1				2	64	128.0	436.7	143.5	489.6
48HP	3	6				1	1	1	64	135.0	460.6	151.0	515.2
50HP	3	6				1		2	64	140.0	477.7	157.0	535.7
52HP	3	6					1	2	64	145.0	494.7	162.0	552.7
54HP	3	6						3	64	150.0	511.8	168.0	573.2
56HP	4	6		2				2	64	156.0	532.3	175.0	597.1
58HP	4	7		1		1	1	1	64	163.0	556.2	182.5	622.7
60HP	4	7		1		1		2	64	168.0	573.2	188.5	643.2
62HP	4	7		1			1	2	64	173.0	590.3	193.5	660.2
64HP	4	7		1				3	64	178.0	607.3	199.5	680.7
66HP	4	8				1	1	2	64	185.0	631.2	207.0	706.3
68HP	4	8				1		3	64	190.0	648.3	213.0	726.8
70HP	4	8					1	3	64	195.0	665.3	218.0	743.8
72HP	4	8						4	64	200.0	682.4	224.0	764.3

Notes:

Capacities are based on the following conditions:

Cooling: Indoor temperature 27°C(80.6°F) DB/19°C(66.2°F) WB; Outdoor temperature 35°C(95°F) DB/24°C(75.2°F) WB

Heating: Indoor temperature 20°C(68°F) DB/15°C(59°F) WB; Outdoor temperature 7°C(44.6°F) DB/6°C(42.8°F) WB

Piping length: Interconnecting piping length is 7.5m(24.6ft), level difference is zero.

The above combination models are factory-recommended models.

*18HP model is customized.

Features

Wide Application Range

Wide range of outdoor units

The outdoor units capacity range from 8HP up to 72HP in 2HP increment. Maximum 64 indoor units with capacity up to 130% of total outdoor units can be connected in one refrigeration system.



Large connectable indoor units quantity

The large quantity of connectable units is suitable for large buildings and projects.

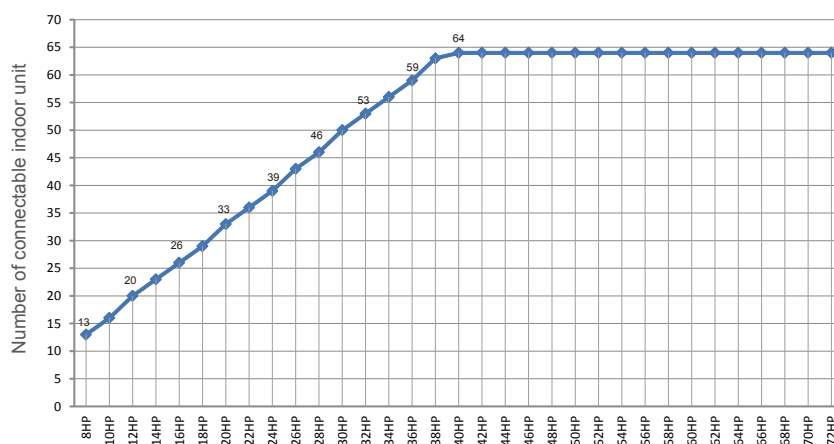

Wide operation range

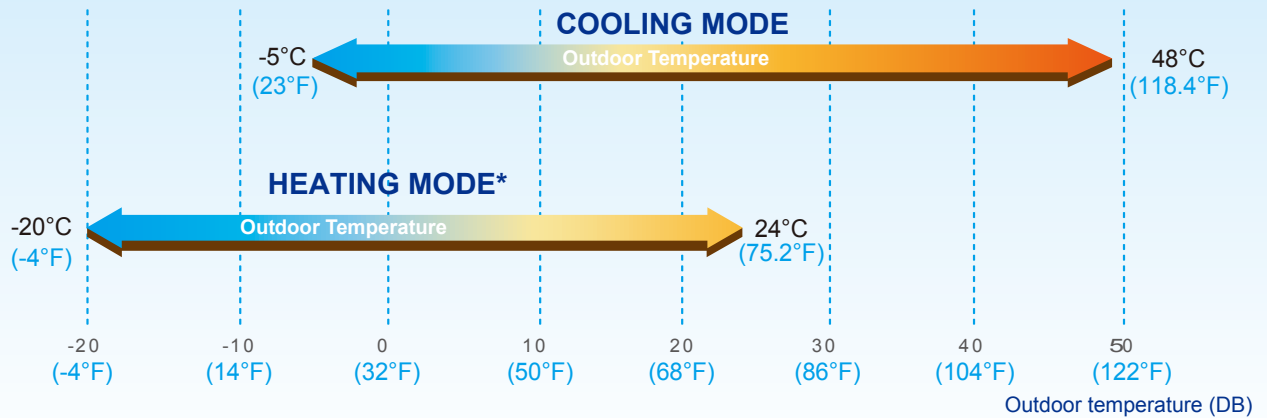

The X-Power series system operates stably at extreme temperatures ranging from -20°C(-4°F) to 48°C(118.4°F).

Long piping length

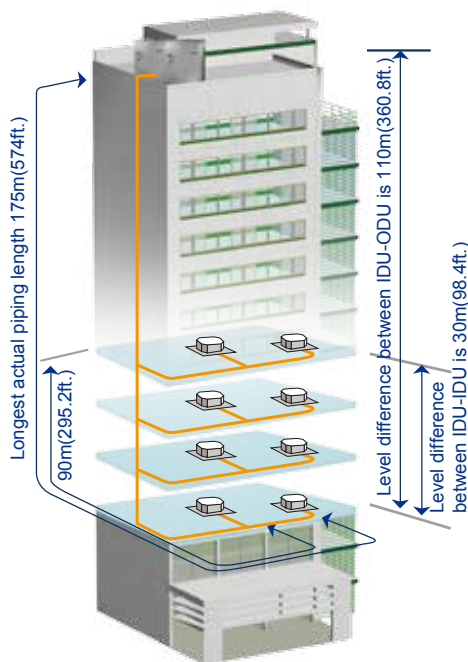

		Permitted value		
		m	ft.	
Piping length	Total piping length (Actual)	1000*	3280*	
	Longest piping	Actual length	175	574
		Equivalent length	200	656
	Equivalent piping length from the farthest IDU to the first indoor branch joint	40/90*	131.2/295.2*	
Level difference	Level difference between IDU-ODU	Outdoor unit up	70	229.6
		Outdoor unit down	110	360.8
	Level difference between IDU-IDU	30	98.4	

*Total pipe length is equal to two times — pipe length plus.

*When the piping length from the farthest IDU to the first indoor branch joint is more than 40m(131.2ft.), it needs to meet specific conditions according to the installation part of the technical manual to achieve 90m(295.2ft.).

High external static pressure

Max. 60Pa(0.24" W.G.) external static pressure can be customized for the outdoor unit, flexible to build-in installation. A standard 0-20Pa(0-0.08" W.G.) external static pressure is equipped by default for all outdoor units. 0-40Pa(0-0.16" W.G.) external static pressure can be customized for 8, 10, 14, 16HP outdoor units, and 0-60Pa(0-24" W.G.) can be customized for 12HP outdoor unit.



High Efficiency

High COP/EER values

The cooling EER up to 4.29 and the heating COP up to 4.39 in the 8HP category.

EER

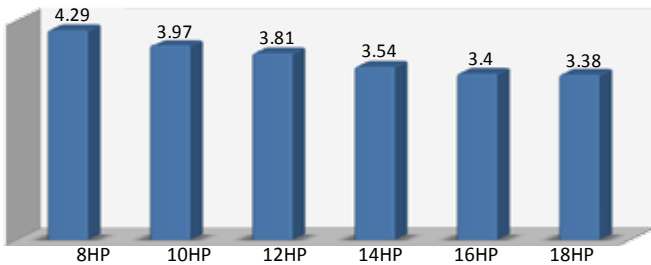

COP

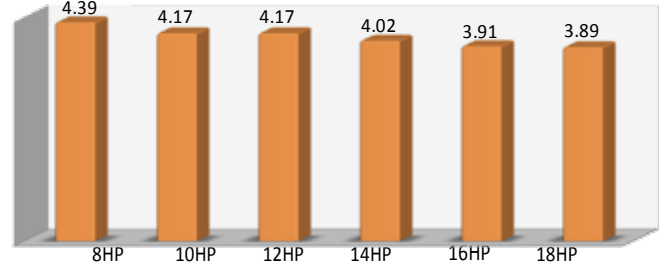

All DC inverter technology

All DC inverter compressors make the capacity output better distributed, and always work at 60-120Hz which is the most efficient range. It makes the efficiency more than 30% higher than the normal.

All DC Inverter Compressors

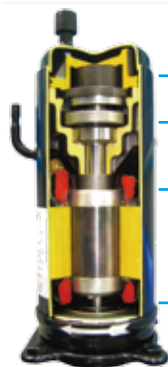

- New structure enhances mid-frequency performance
- Specially designed scroll profile for R410A
- More compact, weight reduced by 50%
- Advanced permanent magnet DC motor improves the low frequency band performance

All DC Fan Motors

According to the running load and system pressure, the system controls the speed of DC fan to achieve the minimum energy consumption and best performance.

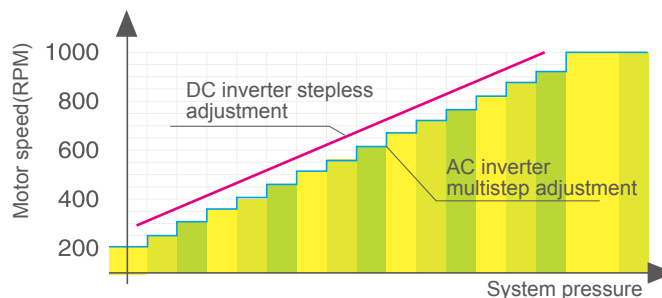

High performance heat exchanger

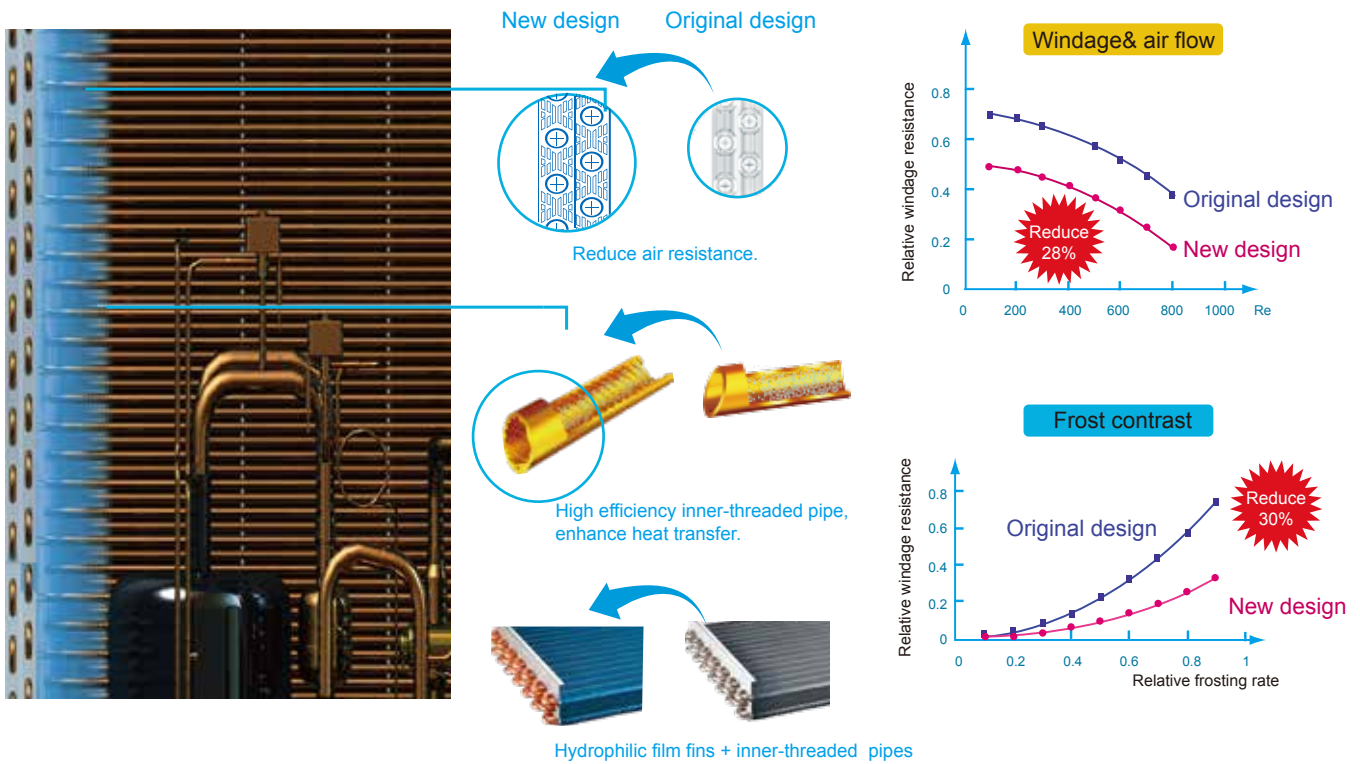

- The new designed window fins enlarge the heat-exchanging area, decrease the air resistance, save more power and enhance heat exchange performance.
- Hydrophilic film fins and inner-threaded copper pipes optimize heat exchange efficiency.

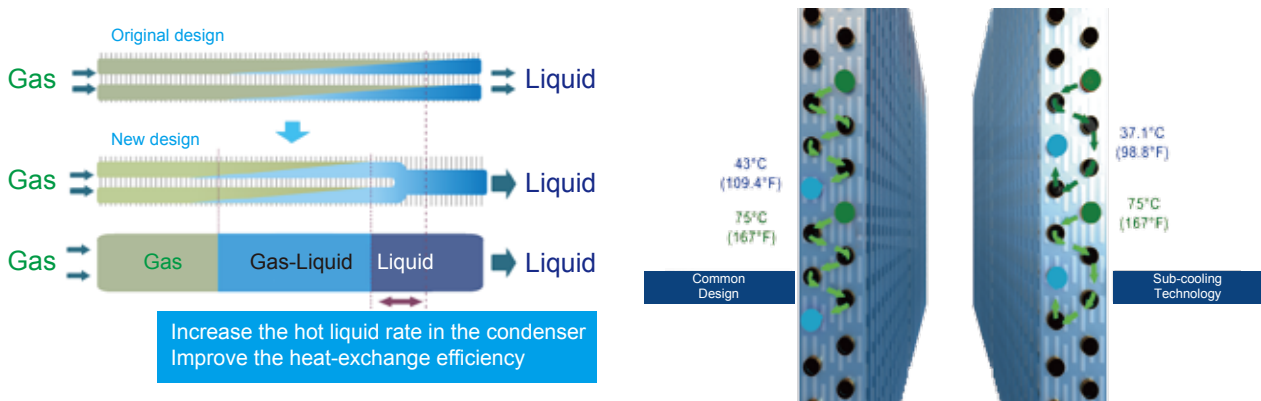

- Innovative designed high efficiency heat exchanger, which can reach up to 12°C(21.6°F) subcooling degree, reduces the system resistance and improves reliability.
- When the outdoor temperature is 35°C(95°F), the refrigerant can be cooled down to 37.1°C(98.8°F), thus achieving high heat-exchanging efficiency with only 2.1°C(3.8°F) temperature difference.

Enhanced Comfort

Night silent operation mode

High comfort outdoor unit's multi-choice of silent mode during the night.
 Super silent operation mode can reduce sound level further, minimum 45dB (A).

Night silent operation will be activated X hours after the peak temperature during daytime, and it will go back to normal operation after Y hours.

- Mode 1→X: 6 hours, Y: 10 hours
- Mode 2→X: 8 hours, Y: 10 hours
- Mode 3→X: 6 hours, Y: 12 hours
- Mode 4→X: 8 hours, Y: 8 hours

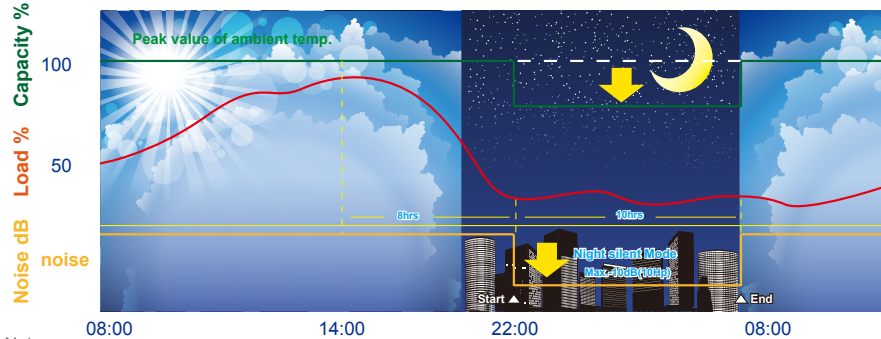

Notes:
 This function can be activated by setting at site. Temperature(load) curve shown in the graph is just an example.

Intelligent defrosting technology

Intelligent defrosting program will judge the defrosting time according to the system real requirement, reduce the heating loss by unnecessary defrosting and make the indoor side more comfortable.

Defrosting time can be shortened to 4 min. due to the specialized defrosting valve.

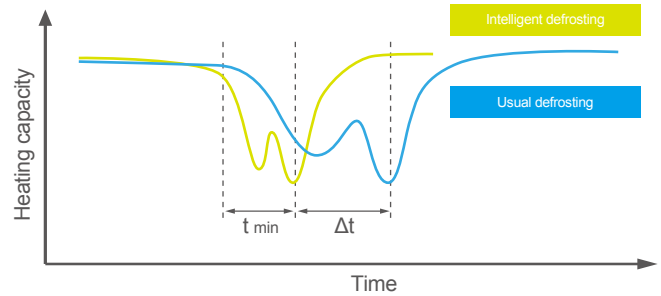

Easier Installation and Service

Simple signal line connection

Centralized controller (CRF-10-CM or CRF-30-CM) can be connected from indoor side or outdoor side (XYE terminals) at will. Only one group of communication wire of PQE, achieved both of communication for indoor & outdoor unit. It's more convenient for communication wiring.

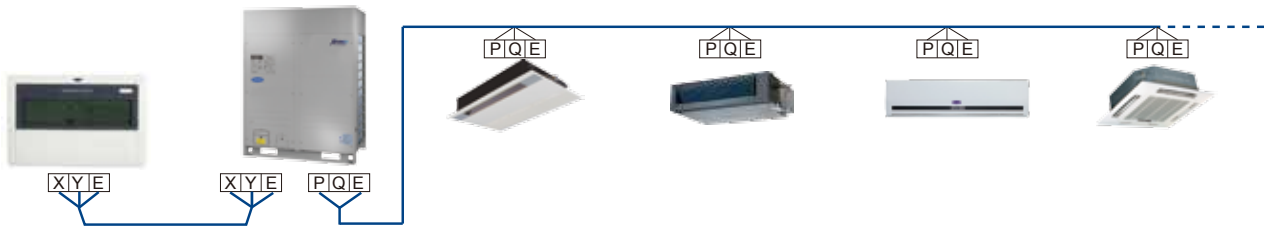

Auto addressing

Outdoor unit can distribute addresses for indoor unit automatically.

Wireless and wired controllers can query and modify each indoor unit's address.



Specifications

X-Power Full Inverter Super S Series

Model			38VF008H117010 38VF008H118010	38VF010H117010 38VF010H118010	38VF012H117010 38VF012H118010
Power supply		V-Ph-Hz	208/230V 3~60Hz 220V 3~50Hz	208/230V 3~60Hz 220V 3~50Hz	208/230V 3~60Hz 220V 3~50Hz
Cooling (*1)	Capacity	kW	25.2	28	33.5
		RT	7.2	8	9.6
	Input	kW	5.88	7.05	8.80
	EER	kW/kW	4.29	3.97	3.81
Heating (*2)	Capacity	kW	27	31.5	37.5
		RT	7.7	9.0	10.7
	Input	kW	6.15	7.55	9.00
	COP	kW/kW	4.39	4.17	4.17
Connectable indoor unit	Total capacity	%	50-130%	50-130%	50-130%
	Max.quantity		13	16	20
Outdoor sound level (*3)		dB(A)	57	57	59
Pipe connections	Liquid side	mm	Φ12.7	Φ12.7	Φ15.9
	Gas side	mm		Φ25.4	Φ31.8
	Oil balance pipe	mm	Φ6.4	Φ6.4	Φ6.4
Compressor	Quantities		1	1	1+1
	Type		DC	DC	DC
	Capacity	Btu/h(W)	31.59	31.59	31.59 +11.80
		Btu/h	107800	107800	107800+40300
	Input	W	10340	10340	10340+3665
	Crankcase	W	27.6×2	27.6×2	27.6×2×2
	Refrigerant oil	Type	FVC68D	FVC68D	FVC68D
ml		500	500	500+1200	
Fan Motor	Type		DC motor	DC motor	DC motor
	Quantities		1	1	2
	Air flow rate	CFM	6620	6620	7660
		m ³ /h	11242	11242	13000
	Output	W	450(rated)	450(rated)	230×2(rated)
ESP.	pa	0-20 (Default) 20-40 (Customize)	0-20 (Default) 20-40 (Customize)	0-20 (Default) 20-40 (Customize)	
Charged refrigerant	Dimension(W×H×D)		960×1615×765	960×1615×765	1250×1615×765
	Packing(W×H×D)		1025×1790×830	1025×1790×830	1305×1790×820
	Net/Gross weight		202/218	202/218	285/305
	type		R410A	R410A	R410A
	volume	kg	9	9	11
Throttle type			EXV	EXV	EXV
Design pressure (High/low)		Mpa	4.4/2.6	4.4/2.6	4.4/2.6
Ambient temperature range	Cooling	°C	-5~48	-5~48	-5~48
	Heating	°C	-20~24	-20~24	-20~24

Specifications

X-Power Full Inverter Super S Series

Model			38VF014H117010 38VF014H118010	38VF016H117010 38VF016H118010	38VF018H117010 38VF018H118010	
Power supply		V-Ph-Hz	208/230V 3~60Hz 220V 3~50Hz	208/230V 3~60Hz 220V 3~50Hz	208/230V 3~60Hz 220V 3~50Hz	
Cooling (*1)	Capacity	kW	40	45	50	
		RT	11.4	12.9	14.3	
	Input	kW	11.30	13.2	14.8	
	EER	kW/kW	3.54	3.4	3.38	
Heating (*2)	Capacity	kW	45	50	56	
		RT	12.9	14.3	16.0	
	Input	kW	11.20	12.8	14.4	
	COP	kW/kW	4.02	3.91	3.89	
Connectable indoor unit	Total capacity	%	50-130%	50-130%	50-130%	
	Max.quantity		23	26	29	
Outdoor sound level (*3)		dB(A)	61	62	62	
Pipe connections	Liquid side	mm	Φ15.9	Φ15.9	Φ19.1	
	Gas side	mm	Φ31.8	Φ31.8	Φ31.8	
	Oil balance pipe	mm	Φ6.4	Φ6.4	Φ6.4	
Compressor	Quantities		1+1	1+1	2	
	Type		DC	DC	DC	
	Capacity	Btu/h(W)	31.59 +11.80	31.59 +11.80	31.590 +31.59	
		Btu/h	107800+40300	107800+40300	107800+107800	
	Input	W	10340+3665	10340+3665	10340 +10340	
	Crankcase	W	27.6×2×2	27.6×2×2	27.6×2×2	
	Refrigerant oil	Type	FVC68D	FVC68D	FVC68D	
ml		500+1200	500+1200	500 + 500		
Fan Motor	Type		DC motor	DC motor	DC motor	
	Quantities		2	2	2	
	Air flow rate	CFM	9200	9200	9200	
		m³/h	15620	15620	15620	
	Output	W	390×2(rated)	390×2(rated)	565×2	
	ESP.	pa	0-20 (Default) 20-40 (Customize)	0-20 (Default) 20-40 (Customize)	0-20 (Default) 20-40 (Customize)	
Charged refrigerant	Dimension(W×H×D)		mm	1250×1615×765	1250×1615×765	
	Packing(W×H×D)		mm	1305×1790×820	1305×1790×820	
	Net/Gross weight		kg	285/305	288/308	310/330
	type			R410A	R410A	R410A
	volume		kg	13	13	16
Throttle type			EXV	EXV	EXV	
Design pressure (High/low)		Mpa	4.4/2.6	4.4/2.6	4.4/2.6	
Ambient temperature range	Cooling	°C	-5~48	-5~48	-5~48	
	Heating	°C	-20~24	-20~24	-20~24	

Specifications

X-Power Full Inverter Super S Series

Model			38VF008H119010	38VF010H119010	38VF012H119010
Power supply		V-Ph-Hz	380~415V 3Ph ~ 50/60Hz	380~415V 3Ph ~ 50/60Hz	380~415V 3Ph ~ 50/60Hz
Cooling (*1)	Capacity	kW	25.2	28	33.5
		RT	7.2	8	9.6
	Input	kW	5.88	7.05	8.8
	EER	W/W	4.29	3.97	3.81
	IPLV		5.6	5.7	5.6
Heating (*2)	Capacity	W	27	31.5	37.5
		RT	7.7	9.0	10.7
	Input	W	6.15	7.55	9
	COP	W/W	4.39	4.17	4.17
Connectable indoor unit	Total capacity	%	50-130%	50-130%	50-130%
	Max.quantity		13	16	20
Outdoor sound level (*3)		dB(A)	57	57	59
Pipe connections	Liquid side	mm	Φ12.7	Φ12.7	Φ15.9
	Gas side		Φ25.4	Φ25.4	Φ31.8
	Oil balance pipe	mm	Φ6.4	Φ6.4	Φ6.4
Max. input consumption		W	11270	11270	16953
Max. current		A	20.8	22.1	30.8
Compressor	Quantities		1	1	1+1
	Type		DC Inverter	DC Inverter	DC Inverter
	Capacity	W	31590(90HZ)	31590(90HZ)	31590(90HZ)+11800(60HZ)
	Input	W	10340(90HZ)	10340(90HZ)	10340(90HZ)+3665(60HZ)
	Crankcase	W	40~80	40~80	40~80
	Oil type		FVC68D	FVC68D	FVC68D
	Oil charge	ml	500	500	500 + 500
Fan Motor	Type		DC Inverter	DC Inverter	DC Inverter
	Quantities		1	1	2
	Output	W	454	454	232×2
	ESP	pa	0~20 (default)	0~20 (default)	0~20 (default)
			20~40 (optional)	20~40(optional)	20~60 (optional)
Air flow rate	m ³ /h	11242	11242	15620	
Outdoor unit	Dimension(W*H*D)	mm	960×1615×765	960×1615×765	1250×1615×765
	Packing (W*H*D)	mm	1025×1790×830	1025×1790×830	1305×1790×820
	Net/Gross weight	Kg	212/227	212/227	288/308
Charged refrigerant type and volume		kg	R410A 10kg	R410A 10kg	R410A 12kg
Throttle type			EXV	EXV	EXV
Excessive operating pressure		MPa	4.4/2.6	4.4/2.6	4.4/2.6
Ambient temp. range - Cooling		℃	-5℃—48℃	-5℃—48℃	-5℃—48℃
Ambient temp. range - Heating		℃	-20℃—27℃	-20℃—27℃	-20℃—27℃

Specifications

X-Power Full Inverter Super S Series

Model			38VF014H119010	38VF016H119010	38VF018H119010
Power supply		V-Ph-Hz	380~415V 3Ph ~ 50/60Hz	380~415V 3Ph ~ 50/60Hz	380~415V 3Ph ~ 50/60Hz
Cooling (*1)	Capacity	kW	40	45	50
		RT	11.4	12.9	14.3
	Input	kW	11.3	13.2	14.8
	EER	W/W	3.54	3.4	3.38
	IPLV		5.5	5.4	5.8
Heating (*2)	Capacity	W	45	50	56
		RT	12.9	14.3	16.0
	Input	W	11.2	12.8	14.4
	COP	W/W	4.02	3.91	3.89
Connectable indoor unit	Total capacity	%	50-130%	50-130%	50-130%
	Max.quantity		23	26	29
Outdoor sound level (*3)		dB(A)	61	62	62
Pipe connections	Liquid side	mm	Φ15.9	Φ15.9	Φ19.1
	Gas side		Φ31.8	Φ31.8	Φ31.8
	Oil balance pipe	mm	Φ6.4	Φ6.4	Φ6.4
Max. input consumption		W	16953	17402	27250
Max. current		A	31.8	32.8	46
Compressor	Quantities		1+1	1+1	1+1
	Type		DC Inverter	DC Inverter	DC Inverter
	Capacity	W	31590(90HZ)+11800(60HZ)	31590(90HZ)+11800(60HZ)	31590(90HZ)+31590(90HZ)
	Input	W	10340(90HZ)+3665(60HZ)	10340(90HZ)+3665(60HZ)	10340(90HZ)+10340(90HZ)
	Crankcase	W	40~80	40~80	27.6×2
	Oil type		FVC68D	FVC68D	FVC68D
	Oil charge	ml	500 + 500	500 + 500	500 + 500
Fan Motor	Type		DC MOTOR	DC MOTOR	DC MOTOR
	Quantities		2	2	2
	Output	W	383×2	383×2	560×2
	ESP	pa	0~20 (default)	0~20 (default)	0~20 (default)
			20~40 (optional)	20~40 (optional)	20~40 (optional)
Air flow rate	m ³ /h	15620	15620	15770	
Outdoor unit	Dimension(W*H*D)	mm	1250×1615×765	1250×1615×765	1250*1615*765
	Packing (W*H*D)	mm	1305×1790×820	1305×1790×820	1305×1790×820
	Net/Gross weight	Kg	288/308	288/308	310/330
Charged refrigerant type and volume		kg	R410A 15kg	R410A 15kg	R410A 16kg
Throttle type			EXV	EXV	EXV
Excessive operating pressure		MPa	4.4/2.6	4.4/2.6	4.4/2.6
Ambient temp. range - Cooling		℃	-5℃—48℃	-5℃—48℃	-5℃—48℃
Ambient temp. range - Heating		℃	-20℃—27℃	-20℃—27℃	-20℃—27℃

Note: 18HP is not the standard model, need to customize

Dimensions

Body dimension

Unit: in.(mm)

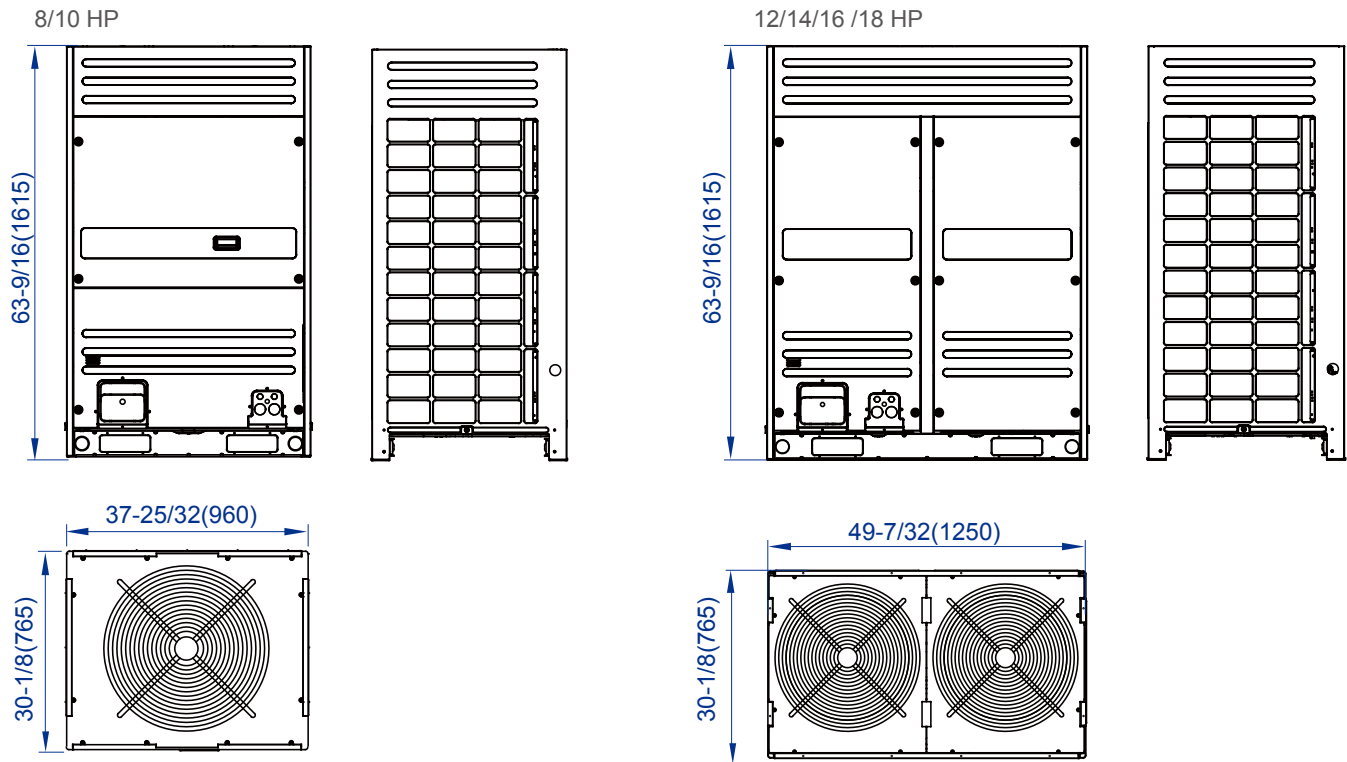

Installation dimension

Unit: in.(mm)

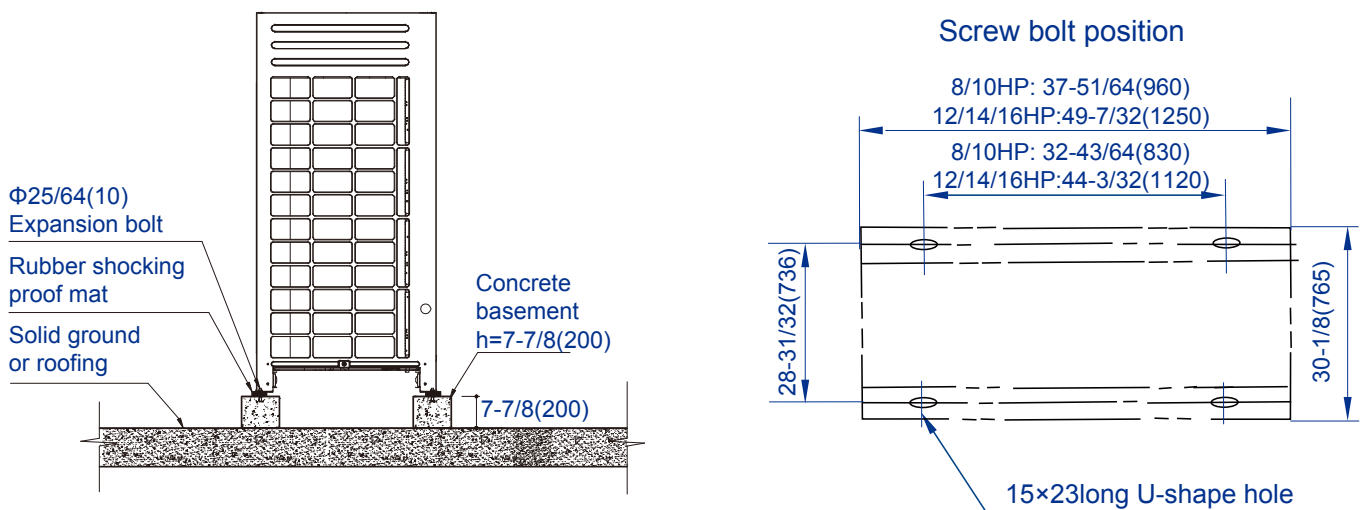

X-Power Full DC Inverter Mini H Series >>



NEW
Fashion
Design



DC Inverter

Features

Wide Application Range

Wide range of outdoor units

The outdoor units' capacity range from 8kW(27,300Btu/h) to 45kW(153,540Btu/h) which is ideal for small offices, villas, apartment and shops, making it perfect for commercial and residential application.



Flexible indoor units connection

Mini VRF with intelligent control gives you independent zoning control with maximum flexibility. A single outdoor unit supports up to nine indoor units, freeing up considerable space outside. Use your backyard more wisely with much more space available created by less number of outdoor units.

- Max. 7 indoor units for a 16kW(52,900Btu/h) outdoor unit installation
- Max. 6 indoor units for a 14kW(47,800Btu/h) outdoor unit installation
- Max. 6 indoor units for a 12kW(40,900Btu/h) outdoor unit installation
- Max. 5 indoor units for a 10.5kW(35,800Btu/h) outdoor unit installation

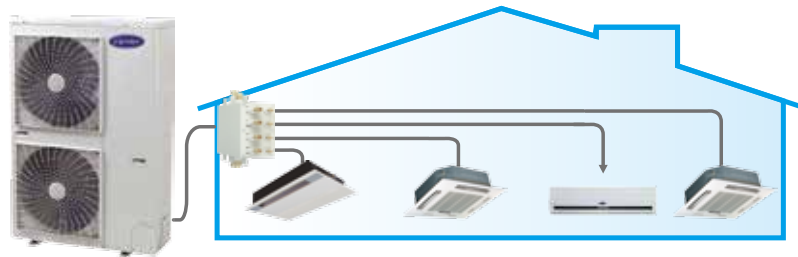

* For 20-45KW unit, please check the information in the specifications.

Wide operation temperature range

Mini VRF system operates stably at extreme temperature range from minus 15°C (5°F) to 43°C(118.4°F).

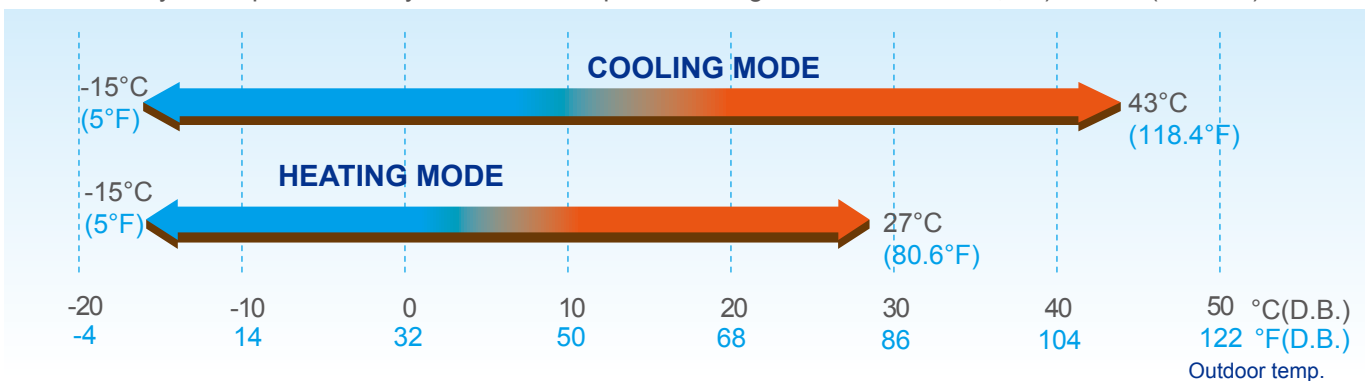

*For 20-45KW unit, please check the information in the following specifications.

Flexible piping design

The Mini VRF provides a total piping length possibility of 100m(328ft), a maximum height difference between outdoor and indoor units of 30m(98.4ft). The height difference between indoors unit can be up to 8m(26.2ft). These generous allowances facilitate an extensive array of system designs.

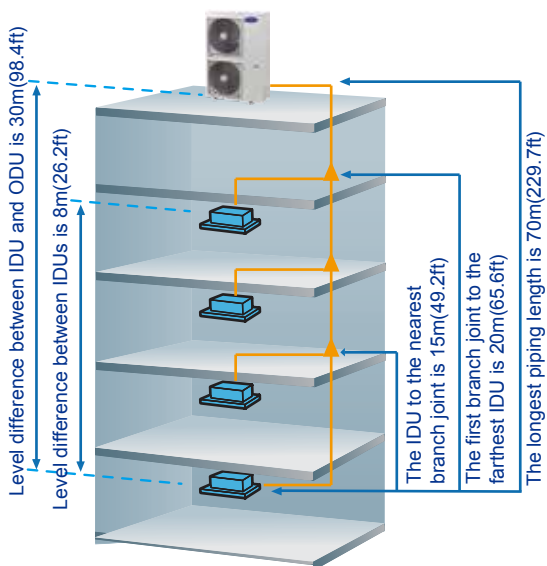

Permitted value		10.5kW (35,800Btu/h)	12/14/16kW (40,900/47,800/52,900Btu/h)	
Piping length	Total piping length (Actual)	100m(328ft)	100m(328ft)	
	Longest piping (L)	Actual length	45m(146.7ft)	
		Equivalent length	50m(164ft)	60m(196.9ft)
Level difference	Equivalent piping length (from the farthest IDU to the first indoor branch jointC)	20m(65.6ft)	20m(65.6ft)	
	Level difference between IDU-ODU	Outdoor unit up	30m(98.4ft)	30m(98.4ft)
		Outdoor unit down	20m(65.6ft)	20m(65.6ft)
	Level difference between IDU-IDU	8m(26.2ft)	8m(26.2ft)	

- 1 Total pipe length is equal to all the liquid pipe or all the gas pipe length.
- 2 When the total equivalent pipe length of liquid side plus gas side is more than 90m(295.2ft), it needs to meet the specific conditions according to the installation part of the technical manual.
- 3 *For 20-45KW unit, please check the information in the specifications.

High Efficiency

High COP and EER values

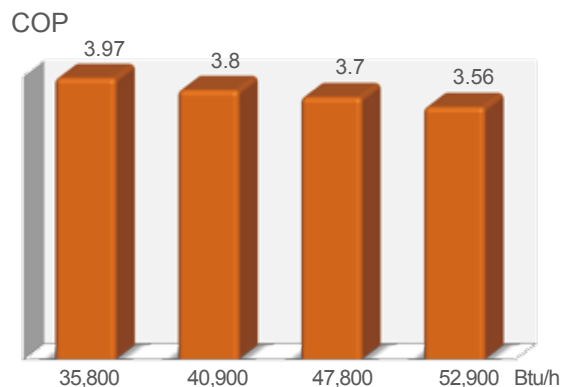
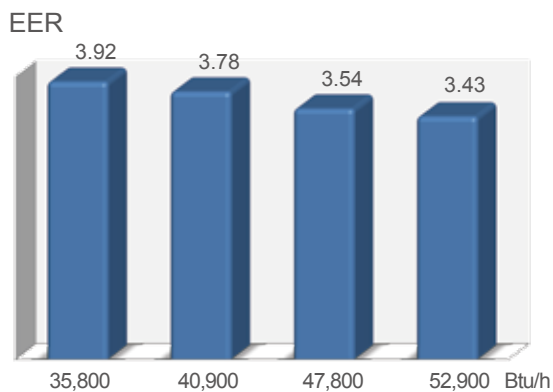

*For 20-45KW unit, please check the information in the specifications.

High performance heat exchanger

Reduce air resistance

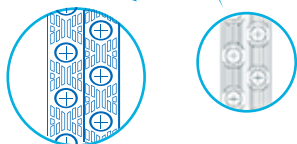

New design

Original design

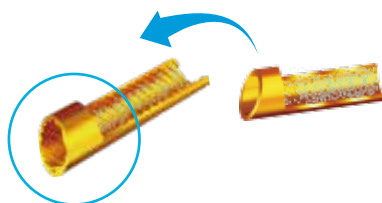

High efficiency inner-threaded pipe, enhance heat transfer.

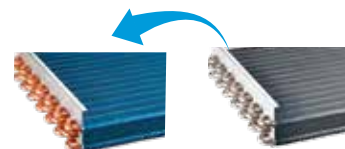

Hydrophilic fins + inner-threaded pipes

- The new designed window fins enlarge the heat-exchanging area, decrease the air resistance, save more power and enhance heat exchange performance.
- Hydrophilic film fins and inner-threaded copper pipes optimize heat exchange efficiency.
- The specially coated blue fins enhance durability and protect against corrosion from air, water and other corrosive agents, assures a longer coil service life.

Easier Installation and Service

Easy installation

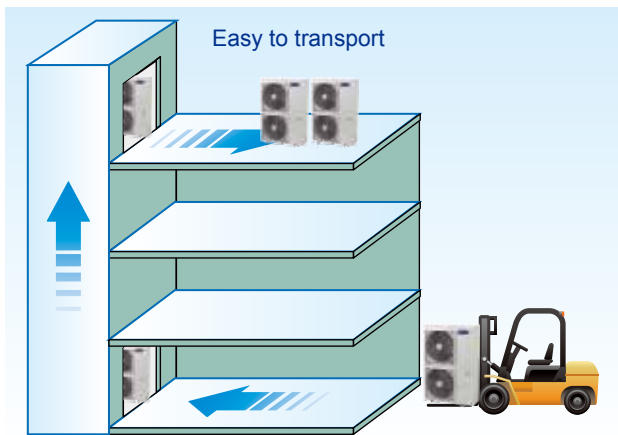

No need special room for the outdoor units.
Easy installation: No special area is required for outdoor units.
Easy transportation: All outdoor units can be transported by elevator, which greatly simplifies installation and reduces time and labor.
The Mini VRF system's indoor and outdoor units are almost as easy to install as residential air conditioning systems, making them ideal for small offices and shops.

Space saving design

The Mini VRF units are slimmer and more compact, resulting in significant savings in installation space. In some large residential and light commercial areas, such as villas, restaurants, usually it need more than one indoor unit, which in turn requires multiple outdoor units. Carrier's MINI VRF system removes this problem, and retains buildings' original aesthetics.



Auto addressing

Addresses of indoor units can be set automatically by outdoor units.
Wireless controller can inquire and modify every indoor units address.

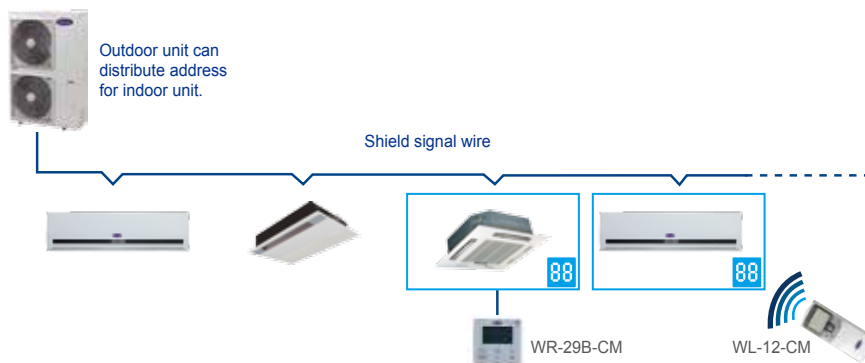

More convenience in installation

A four-direction space is available for connecting pipes and wiring in various installation sites.

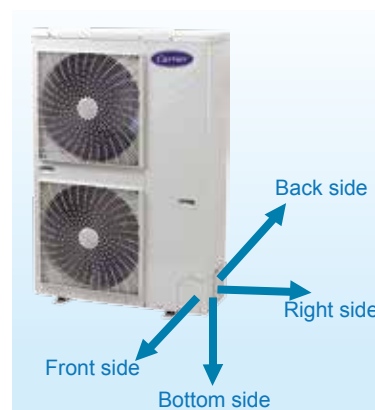
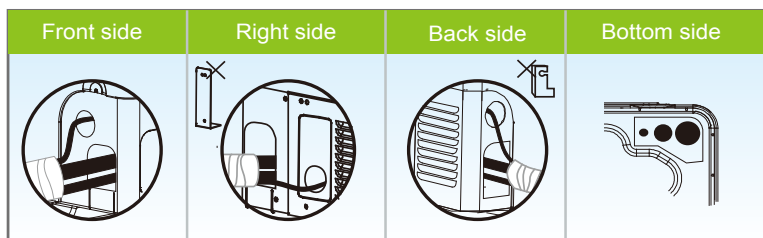

More convenient piping connector - branch box

Easier and safer installation thanks to a branch box that simplifies piping work and the adoption of screw connection.

Both left and right pipe flare connection from outdoor unit to branch box is reserved, which greatly simplifies field installation.

Two sets of pipe size converter are packed with branch box to transfer the pipe size from $\Phi 6.35\text{mm}(\Phi 1/4\text{in})$ to $\Phi 9.53\text{mm}(\Phi 3/8\text{in})$ and from $\Phi 12.7\text{mm}(\Phi 1/2\text{in})$ to $\Phi 15.9\text{mm}(\Phi 5/8\text{in})$.

■ Low noise

The branch pipe is linear expansion design regulates the flow of refrigerant and reduces the noise. By locating the branch box in the ceiling or outside, noise generated by the branch box can be kept clear of living spaces, thus makes noise level to a minimum.



■ Brazing-free quick installation

All the piping leading to and from the branch box is connected using screw joints, which can be installed quickly and easily.

■ Indoor installation

The branch box can be installed in the ceiling rather than outside. Removing the side and bottom covers provides easy access for maintaining inner components such as circuit boards.

New piping connection design

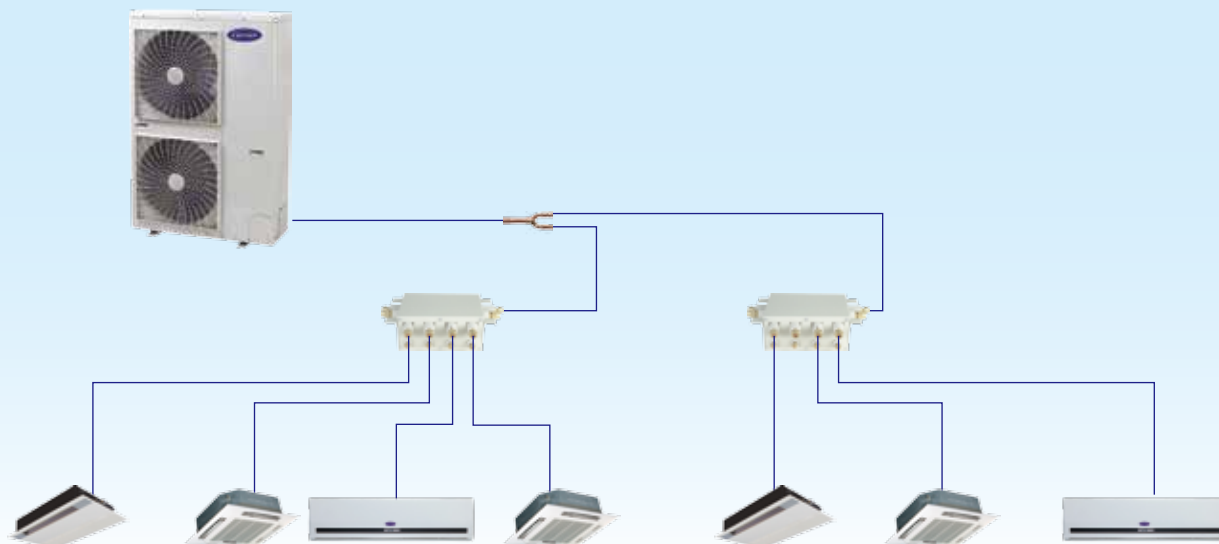

*40/45KW unit can not connect branch box

Advanced Technologies

Full DC inverter technology

At the heart of our system is a highly intelligent inverter driven compressor. This advanced technology enables the output of the outdoor unit to be modulated by the cooling or heating demands of the zone that it controls. This advanced system ensures precise temperature regulation and highly efficient energy usage, making a significant contribution to the limiting the impact on the environment.

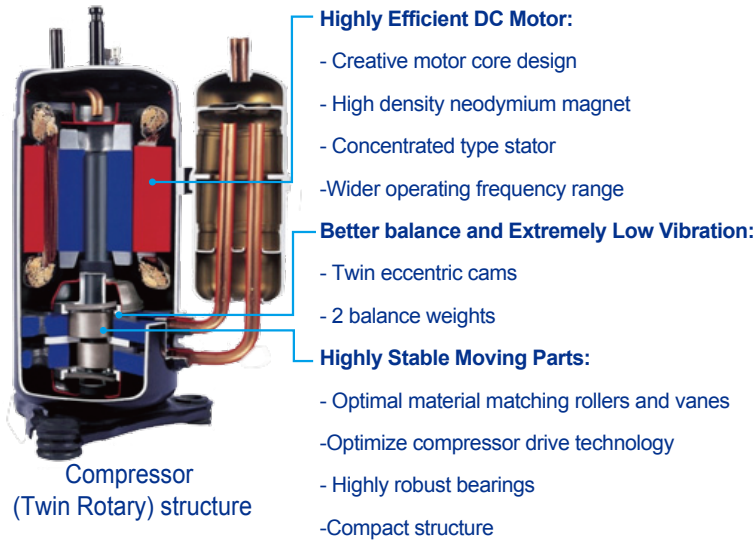

High efficiency DC fan motor saved power up to 50%.

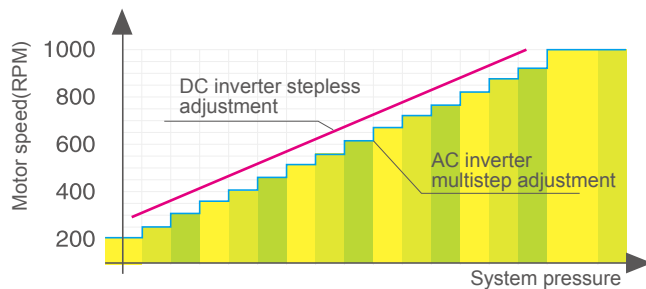

Noise reducing design

Optimally designed fan shape and air discharge grille increases air volume and reduces running noise.

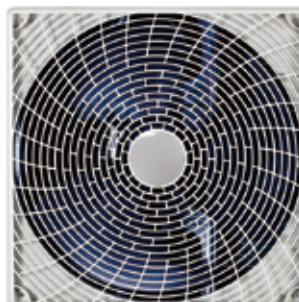
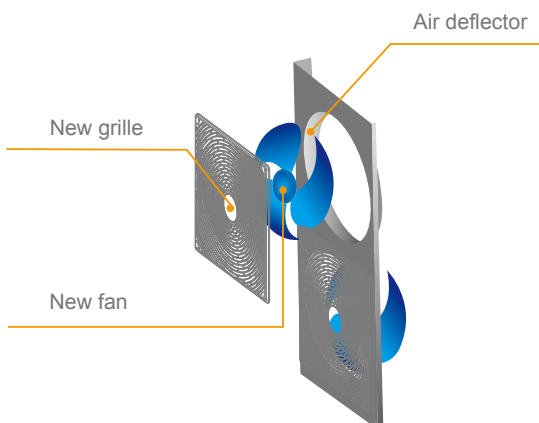

Newly Designed Fan Guard

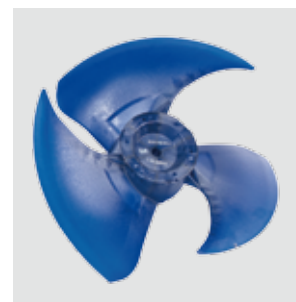

Powerful Large Propeller

Outdoor Unit



380/415V~3Ph~60Hz

38VR004H118010
38VR005H118010
38VR006H118010

380/415V~3Ph~50Hz

38VR004H119010 38VR007H119010 38VR014H11901S
38VR005H119010 38VR008H11901S 38VR016H11901S
38VR006H119010 38VR010H11901S

Specifications 60Hz&50Hz

Sales Model			38VR004H118010	38VR005H118010	38VR006H118010
Power supply		V-Ph-Hz	380-415V-3Ph-60Hz	380-415V-3Ph-60Hz	380-415V-3Ph-60Hz
Cooling	Capacity	kW	12	14	15.5
		RT	3.4	4.0	4.4
	Input	kW	3.25	3.95	4.52
	EER	kW/ kW	3.69	3.54	3.43
Heating	Capacity	kW	13.2	15.4	17
		RT	3.8	4.4	4.9
	Input	kW	3.47	4.16	4.77
	COP	kW/ kW	3.8	3.7	3.56
Outdoor sound level (*3)		dB(A)	57	57	57
Pipe connections	Liquid side	mm	Φ9.53	Φ9.53	Φ9.53
	Gas side	mm	Φ15.9	Φ15.9	Φ19.1
Connectable	Total capacity	%	50-130%	50-130%	50-130%
	Max.quantity		6	6	7
Compressor	Type		Rotary	Rotary	Rotary
	Brand		MITSUBISHI	MITSUBISHI	MITSUBISHI
	Capacity	kW	9.88	9.88	13.98
	Crankcase	W	27	27	25
	Refrigerant oil	Type	FV50S	FV50S	FV50S
	Refrigerant oil	ml	870	870	1400
Fan Motor	Type		DC motor	DC motor	DC motor
	Quantity		2	2	2
	Output	W	2 x85	2 x85	2 x 85
	Airflow	CFM	4100	3824	3530
m ³ /h		6983	6500	6000	
Outdoor unit	Dimension(W x H x D)	mm	900 x 1327 x 400	900 x 1327 x 400	900 x 1327 x 400
	Packing (W x H x D)	mm	1030 x 1456 x 435	1030 x 1456 x 435	1030 x 1456 x 435
	Net/Gross weight	kg	92/106	95/106	102/113
Refrigerant	Type		R410A	R410A	R410A
	Charged volume	g	3300	3900	3900
Throttle type			EXV		
Design pressure		MPa	4.4/2.6		
Ambient temp		°F (°C)	15~43 C		
			-15~27 C		

Note:

- The cooling conditions: indoor temp.: 27°C DB(80.6 °F), 19 °C WB(60°F) outdoor temp.: 35°C DB(95°F) equivalent pipe length: 5m drop length: 0m.
- The heating conditions: indoor temp.: 20°C DB(68°F), 15°C WB(44.6°F) outdoor temp.: 7 °C DB(42.8°F) equivalent pipe length: 5m drop length: 0m.
- Sound level: Anechoic chamber conversion value, measured at a point 1 m(3.28ft) in front of the unit at a height of *m(1m(3.28ft) for 105 model,1.2m(3.94ft) for 120~160model). During actual operation, these values might be higher as a result of ambient conditions.
- The above data may be changed without notice for future improvement on quality and performance.

DC inverter MINI H series-3p

■ Specifications 50Hz

Sale Model			38VR004H119010	38VR005H119010	38VR006H119010
Power supply		V-Ph-Hz	380-415V-3N~50Hz	380-415V-3N~50Hz	380-415V-3N~50Hz
Cooling	Capacity	kW	12	14	15.5
		RT	3.4	4.0	4.4
	Input	kW	3.9	4.75	5.6
	EER		3.08	2.95	2.77
Heating	Capacity	kW	13.2	15.4	17
		RT	3.8	4.4	4.9
	Input	kW	3.75	4.55	5.4
	COP		3.52	3.38	3.15
Connectable indoor unit	Total capacity	%	50-130%	50-130%	50-130%
	Max.quantity		6	6	7
Outdoor sound level (sound pressure level)		dB(A)	57	57	57
Refrigerant Pipe	Liquid side	mm	Φ9.52	Φ9.52	Φ9.52
	Gas side	mm	Φ15.9	Φ15.9	Φ15.9
Compressor	Type		Rotary	Rotary	Rotary
	Brand		mitsubishi	mitsubishi	mitsubishi
	Capacity	Btu/h	33720	33720	47700
	Crankcase	W	27	27	25
	Refrigerant oil	ml	FV50S 870ml	FV50S 870ml	FV50S 1400ml
Fan motor	Quantities		2	2	2
	Type		DC motor	DC motor	DC motor
	Air flow rate	m³/h	6000	6000	6000
		CFM	3529	3529	3529
Outdoor unit	Dimension(W*H*D)	mm	900*1327*320	900*1327*320	900*1327*320
	Packing (W*H*D)	mm	1030*1456*435	1030*1456*435	1030*1456*435
	Net/Gross weight	kg	95/106	95/106	102/113
Refrigerant	Type		R410A	R410A	R410A
	Charged volume	g	3300	3900	3900
Throttle type			EXV	EXV	EXV
Design pressure	MPa		4.4/2.6	4.4/2.6	4.4/2.6
Ambient temp	°C		Cooling -15~43	Cooling -15~43	Cooling -15~43
			Heating -15~27	Heating -15~27	Heating -15~27

Note:

- The cooling conditions: indoor temp.: 27°C DB(80.6 °F), 19 °C WB(60°F) outdoor temp.: 35°C DB(95°F) equivalent pipe length: 5m drop length: 0m.
- The heating conditions: indoor temp.: 20°C DB(68°F), 15°C WB(44.6°F) outdoor temp.: 7 °C DB(42.8°F) equivalent pipe length: 5m drop length: 0m.
- Sound level: Anechoic chamber conversion value, measured at a point 1 m(3.28ft) in front of the unit at a height of *m(1m(3.28ft) for 105 model,1.2m(3.94ft) for 120~160model). During actual operation, sound level might be affected by ambient conditions.
- The above data may be changed without notice for future improvement on quality and performance.

■ Specifications 50Hz

Sales Model			38VR007H119010	38VR008H11901S	38VR010H11901S	38VR014H11901S	38VR016H11901S	
Power supply		V-Ph-Hz	380-415V-3N~50Hz	380-415V-3N~50Hz	380-415V-3N~50Hz	380-415-3N~50	380-415-3N~50	
Cooling	Capacity	kW	20	22.4	26	40	45	
		RT	5.7	6.4	7.4	11.4	12.9	
	Input	kW	6.63	7.2	8.4	11.9	13.6	
	EER	KW/KW	3.02	3.11	3.09	3.35	3.32	
Heating	Capacity	kW	22	24.5	28.5	45	50	
		RT	6.29	7	8.1	12.86	14.3	
	Input	kW	5.95	6.7	7.9	11.1	12.7	
	COP	KW/KW	3.69	3.66	3.6	4.05	3.93	
Outdoor sound level(*3)		dB(A)	59	59	60	62	62	
Pipe connections	Liquid side	mm	Φ9.53	Φ9.53	Φ9.53	Φ12.7	Φ12.7	
	Gas side	mm	Φ19.1	Φ19.1	Φ22.2	Φ22.2	Φ25.4	
Connectable	Total capacity	%	50-130%	50-130%	50-130%	50-130%	50-130%	
	Max. quantity		10	11	12	14	15	
Compressor	Type		Rotary	Rotary	Rotary	Rotary	Rotary	
	Brand		MITSUBISHI	MITSUBISHI	MITSUBISHI	MITSUBISHI	MITSUBISHI	
	Capacity	Btu/h	13980	16860	16860	13980×2	16860×2	
	Crankcase	W	25	25	25	25×2	25×2	
	Refrigerant oil	Type	FV50S	FV50S	FV50S	FV50S	FV50S	
	Refrigerant oil	ml	1400+1300	1700+1500	1700+1500	1400×2+2500	1700×2+3600	
Fan Motor	Type		DC motor	DC motor	DC motor	DC+AC	DC+AC	
	Quantity		2	2	2	1+1	1+1	
	Output	W	210/160	200/150	200/150	560/320	560/320	
	Airflow	CFM		6470	6173	6173	9750	9750
		m³/h		10999	10494	10494	16575	16575
Outdoor unit	Dimension(W x H x D)	mm	1120×1558×400	1120×1558×400	1120×1558×400	1360×1650×540	1460×1650×540	
	Net/Gross weight	kg	137/153	146.5/162.5	147/163	240/260	275/290	
Refrigerant	Type		R410A	R410A	R410A	R410A	R410A	
	Charged volume	g	4800	6200	6200	9000	12000	
Throttle type			EXV					
Design pressure	MPa		4.4/2.6					
Ambient temp	°F(°C)		-5~48	-5~48	-5~48	-5~48	-5~48	
			-15~27	-15~27	-15~27	-15~24	-15~24	

Note:

1. The cooling conditions: indoor temp.: 27°C DB(80.6°F), 19°C WB(60°F) outdoor temp.: 35°C DB(95°F) equivalent pipe length: 5m drop length: 0m.
2. The heating conditions: indoor temp.: 20°C DB(68°F), 15°C WB(44.6°F) outdoor temp.: 7°C DB(42.8°F) equivalent pipe length: 5m drop length: 0m.
3. Sound level: Anechoic chamber conversion value, measured at a point 1 m(3.28ft) in front of the unit at a height of *m(1m(3.28ft) for 105 model,1.2m(3.94ft) for 120~160model). During actual operation, sound level might be affected by ambient conditions.
4. The above data may be changed without notice for future improvement on quality and performance.

Outdoor Unit

208/230V~1Ph~60Hz

38VR004H11301S
38VR004H11301O
38VR005H11301O
38VR006H11301O

220-240V~1Ph~50Hz

38VR003H11201O 38VR005H11201O
38VR004H11201S 38VR006H11201O
38VR004H11201O



■ Specifications 60Hz&50Hz

Sale Model			38VR004H11301S	38VR004H11301O	38VR005H11301O	38VR006H11301O
Power supply		V-Ph-Hz	208-230V-1Ph~60Hz	208-230V-1Ph~60Hz	208-230V-1Ph~60Hz	208-230V-1Ph~60Hz
Cooling	Capacity	kW	10.5	12	14	15.5
		RT	3	3.4	4.0	4.4
	Input	kW	2.68	3.25	3.95	4.52
	EER	kW/kW	3.92	3.69	3.54	3.43
Heating	Capacity	kW	11.5	13.2	15.4	17
		RT	3.3	3.8	4.4	4.9
	Input	kW	2.9	3.47	4.16	4.77
	COP	kW/kW	3.97	3.80	3.70	3.56
Coneectable indoor unit	Total capacity	%	50-130%	50-130%	50-130%	50-130%
	Max.quantity		5	6	6	7
Outdoor sound level (*3)		dB(A)	57	57	57	57
Pipe connections	Liquid side	mm	Φ9.53	Φ9.53	Φ9.53	Φ9.53
	Gas side	mm	Φ15.9	Φ15.9	Φ15.9	Φ19.1
Compressor	Type		Rotary	Rotary	Rotary	Rotary
	Brand		MITSUBISHI	MITSUBISHI	MITSUBISHI	MITSUBISHI
	Capacity	Btu/h	24330	33710	33710	47713
	Input	W	2200	3010	3010	14573
	Crankcase	W	25	27	25	20
	Refrigerant oil	Type	FV50S	FV50S	FV50S	FV50S
		ml	870	870	870	1400
Fan Motor	Type		DC motor	DC motor	DC motor	DC motor
	Quantity		1	2	2	2
	Output	W	170	2 x 85	2 x 85	2 x 85
	Air floor rate	CFM	3000	3531	3531	3531
m ³ /h		5100	6000	6000	6000	
Outdoor unit	Dimension (W x H x D)	mm	1075x966x396	900x1327x400		
	Packing (W x H x D)	mm	1120x1100x435	1030x1456x435		
	Net/Gross weight	kg	78/85	95/106	95/106	102/113
Refrigerant	Type		R410a			
	Charged volume	kg	3	3.3	3.9	3.9
Throttle type			EXV	EXV	EXV	EXV
Design pressure		MPa	4.4/2.6	4.4/2.6	4.4/2.6	4.4/2.6
Ambient temperature range	Cooling	°C	-15~43 C			
	Heating	°C	-15~27 C			

Note:

1. The cooling conditions: indoor temp.: 27°C DB(80.6°F), 19°C WB(60°F) outdoor temp.: 35°C DB(95°F) equivalent pipe length: 5m drop length: 0m.
2. The heating conditions: indoor temp.: 20°C DB(68°C), 15°C WB(44.6°F) outdoor temp.: 7°C DB(42.8°F) equivalent pipe length: 5m drop length: 0m.
3. Sound level: Anechoic chamber conversion value, measured at a point 1 m in front of the unit at a height of *m(0.9m for 80model, 1m for 105 model, 1.2m for 120~160model). During actual operation, these values are normally somewhat higher as a result of ambient conditions.
4. The above data may be changed without notice for future improvement on quality and performance.

DC Inverter Mini H Series

Specifications 50Hz

Model			38VR003H112010	38VR004H11201S	38VR004H112010	38VR005H112010	38VR006H112010
Power supply		V-Ph-Hz	220-240V-1PH-50Hz	220-240V-1PH-50Hz	220-240V-1PH-50Hz	220-240V-1PH-50Hz	220-240V-1PH-50Hz
Cooling	Capacity	kW	8	10	12	14	15.5
		RT	2.3	2.9	3.4	4.0	4.4
	Input	kW	3.4	3.75	3.95	4.85	5.65
	EER		2.35	2.67	3.04	2.89	2.74
Heating	Capacity	kW	9	11.5	13.2	15.4	17
		RT	2.6	3.3	3.8	4.4	4.9
	Input	kW	2.8	3.5	3.55	4.35	5.5
	COP		3.21	3.29	3.72	3.54	3.09
Connectable indoor unit	Total capacity	%	50-130%	50-130%	50-130%	50-130%	50-130%
	Max.quantity		4	5	6	6	7
Outdoor sound level (sound pressure level)		dB(A)	56	57	57	57	59
Refrigerant Pipe	Liquid side	mm	Φ9.52	Φ9.52	Φ9.52	Φ9.52	Φ9.52
	Gas side	mm	Φ15.9	Φ15.9	Φ15.9	Φ15.9	Φ15.9
Compressor	Type		Rotary	Rotary	Rotary	Rotary	Rotary
	Brand		MITSUBISHI	MITSUBISHI	MITSUBISHI	MITSUBISHI	MITSUBISHI
	Capacity	Btu/h	24334	24334	33642	33642	47700
	Crankcase	W	25	25	25	25	25
	Refrigerant oil	ml	FV50S 670ml+200ml	FV50S 670ml+200ml	FV50S 870ml+630ml	FV50S 870ml+630ml	FV50S 1400ml+250ml
Fan motor	Quantities		1	1	2	2	2
	Type		DCmotor	DCmotor	DCmotor	DCmotor	DCmotor
	Brand		Panasonic	Panasonic	Panasonic	Panasonic	Panasonic
	Output	W	170	170	2*85	2*85	2*85
	Air flow rate	m³/h	5500	5500	6000	6000	6000
CFM		3235	3235	3529	3529	3529	
Outdoor unit	Dimension(W*H*D)	mm	1075*966*396	1075*966*396	900*1327*320	900*1327*320	900*1327*320
	Packing (W*H*D)	mm	1105x1005x435	1105*1005*435	1030*1456*435	1030*1456*435	1030*1456*435
	Net/Gross weight	kg	62/67	72/79	95/106	95/106	100/111
Refrigerant	Type		R410A	R410A	R410A	R410A	R410A
	Charged volume	g	2800	3000	3300	3900	3900
Throttle type			EXV	EXV	EXV	EXV	EXV
Design pressure	MPa		4.4/2.6	4.4/2.6	4.4/2.6	4.4/2.6	4.4/2.6
Ambient temp	℃	Cooling	-15~43	-15~43	-15~43	-15~43	-15~43
		Heating	-15~27	-15~27	-15~27	-15~27	-15~27

Dimension

Unit Dimensions, unit: mm(in)

8/10.5kW

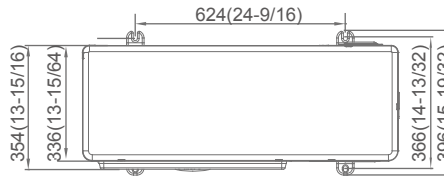
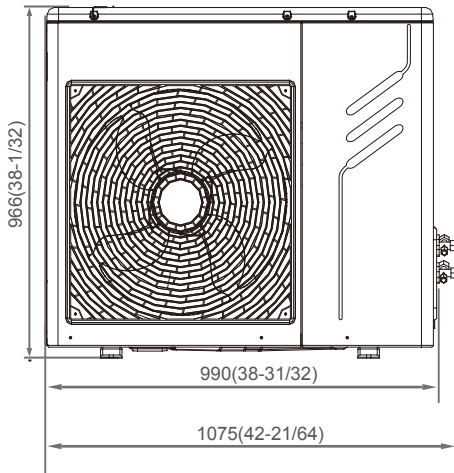

12/14/16kW

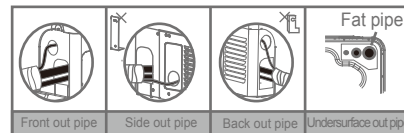
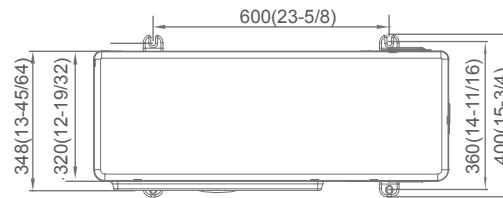
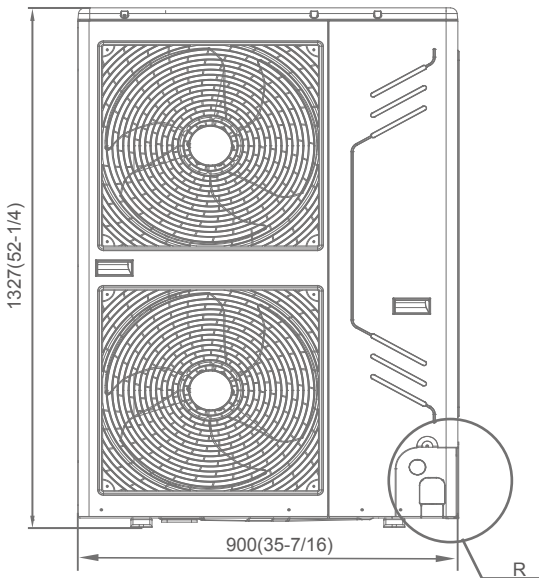

R amplification

Unit installation

Single Unit installation

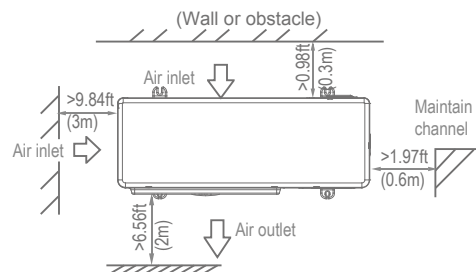
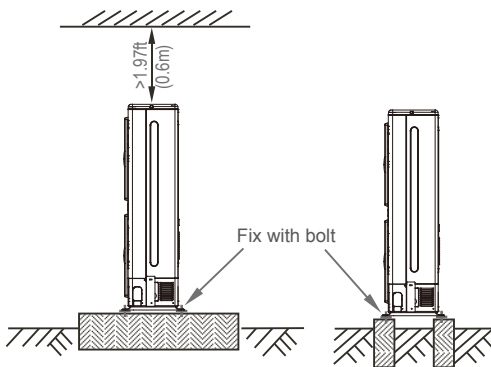



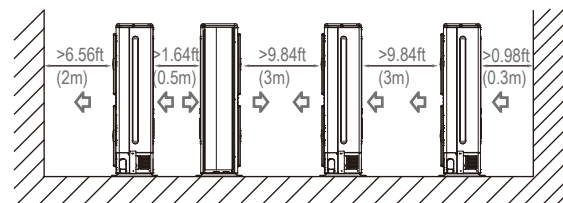
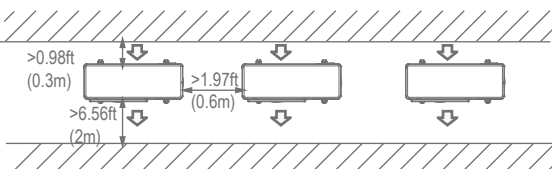







Parallel installation



Indoor Units Lineup >>

- One-way Cassette
- Two-way Cassette
- Compact Four-way Cassette
- Standard Four-way Cassette
- Low Static Pressure Duct
- Concealed Duct Unit (A5 Type)
- High Static Pressure Duct
- Ceiling&Floor
- Wall-mounted
- Fresh Air Processing Unit

Type		Model	18	22	28	36
		kW	1.8	2.2	2.8	3.6
		Btu/h	6,100	7,500	9,600	12,300
		Ton	0.5	0.6	0.8	1
		HP	0.6	0.8	1	1.25
One-way Cassette	40VZ***H11200011 40VZ***H11300011		●	●	●	●
Two-way Cassette	40VT***H11300010 40VT***H10200010			●	●	●
Compact Four-way Cassette	40VX***H11300010 40VX***H11200010			●	●	●
Four-way Cassette	40VK***H11300011 40VK***H11200011				●	●
Low Static Pressure Duct	42VD***H113002011 42VD***H112002011		●	●	●	●
Concealed Duct Unit(A5 Type)	42VD***H113003010 42VD***H112003010					
	42VD***H113003011 42VD***H112013011			●	●	●
High Static Pressure Duct	42VD***H113011010 42VD***H112011010					
						
	42VD***H113011010 42VD***H112011010					
Ceiling & Floor	42VF***H113000010 42VF***H112000010					●
						
Wall-mounted	42VH***H113000101 42VH***H112000101			●	●	●
	42VH***H113000100 42VH***H112000102					
Fresh Air Processing Unit	42VD***H113211010 42VD***H112211010					
						

11 types and more than 100 models are available to meet varied customer requirements.

	45	56	71	80	90	100	112	125	140	160	200	250	280	400	450	560
	4.5	5.6	7.1	8.0	9.0	10.0	11.2	12.5	14.0	16.0	20.0	25.0	28.0	40.0	45.0	56.0
	15,400	19,100	24,200	27,300	30,700	34,100	38,200	42,700	47,800	54,600	68,200	85,300	95,500	136,500	153,500	170,600
	1.3	1.6	2.0	2.3	2.6	2.9	3.2	3.5	4.0	5.0	5.7	7.1	8	11.4	12.8	16
	1.6	2	2.5	2.8	3.2	3.6	4	4.5	5	6	8	9	10	14	16	20
●	●	●														
●	●	●														
●																
●	●	●	●	●	●	●	●		●							
●	●	●														
			●	●			●		●							
●	●	●														
		●	●	●			●									
									●	●						
											●	●	●			
														●	●	●
●	●	●	●	●	●		●		●	●						
●	●															
		●	●	●												
								●	●							
											●	●	●			

One-way Cassette



-  Auto Restart
-  Auto Addressing
-  Follow Me
-  LED Display
-  Fresh Air
-  Cleanable Panel
-  Anti-Cold Air Function
-  Built-in Drain Pump

Only 153mm thickness

Compact design, ultra slim body with a minimum thickness of 153mm for model 18-36, especially suitable for narrow ceiling, such as in lobbies and small meeting rooms.

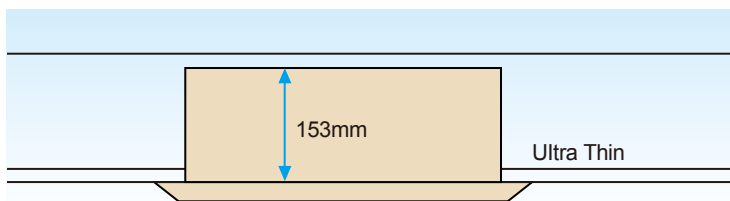

Standard built-in drain pump with 750mm pump head.

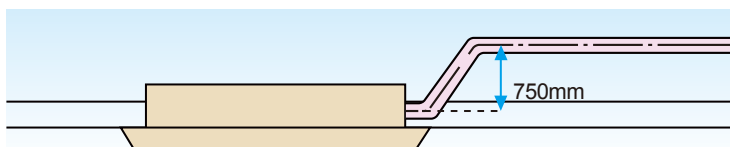

Auto swing

Auto swing mechanism guarantees even airflow distribution and a better room temperature balance.

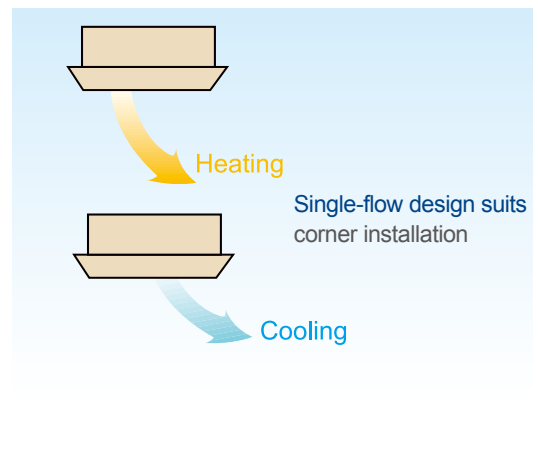

Fresh air, improved air quality

Reserved fresh air intake port for high quality air creates a comfortable and healthy environment. Only for 4.5-7.1kw unit.



Special enzyme sterilization and filtering technologies filter bacteria, smog, and pollen. Provide a clean, healthy and natural air supply.

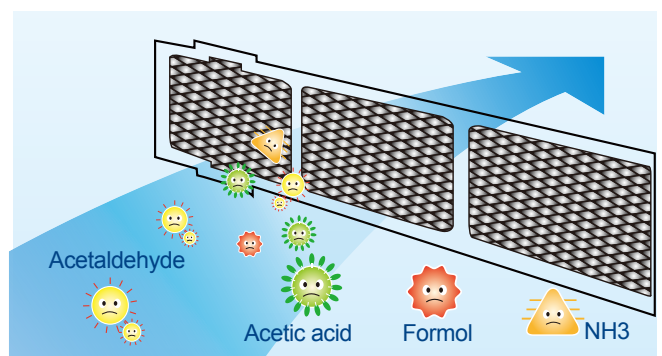

Specifications 60Hz

Model		40VZ006H11300011	40VZ007H11300011	40VZ009H11300011	40VZ012H11300011	40VZ016H11300011	40VZ020H11300011	40VZ024H11300011	
Power Supply		V-Ph-Hz	208-230V-1Ph-60Hz						
Cooling	Capacity	kW	1.8	2.2	2.8	3.6	4.5	5.6	7.1
		Btu/h	6100	7500	9600	12300	15400	19100	24200
	Input	W	41	41	41	41	54	60	75
	Rated current	A	0.24	0.24	0.25	0.25	0.27	0.32	0.36
Heating	Capacity	kW	2.2	2.6	3.2	4	5	6.3	8
		Btu/h	7500	8900	10900	13600	17100	21500	27300
	Input	W	41	41	41	41	44	50	65
	Rated current	A	0.24	0.24	0.25	0.25	0.27	0.32	0.36
Indoor air flow(H/M/L)		m³/h	523/404/275	523/404/275	573/456/315	573/456/315	693/600/476	792/688/549	933/749/592
		CFM	308/238/162	308/238/162	337/268/185	337/268/185	408/353/280	466/405/323	549/441/349
Indoor noise level(H/M/L)		dB(A)	37/34/30	38/34/30	39/37/34	40/38/34	41/39/35	42/40/36	44/41/37
Indoor unit	Dimension(WxHxD)	mm	1054×153×425				1204×189×443		
	Packing(WxHxD)	mm	1155×245×490				1370×295×505		
	Net/Gross weight	kg	12.5/16		13/16.5		18.5/23.2	18.8/23.5	19.5/24.2
Panel	Dimension(WxHxD)	mm	1180×25×465				1350×25×505		
	Packing(WxHxD)	mm	1232×107×517				1410×95×560		
	Net/Gross weight	kg	3.5/5.2				4/5.4		
Refrigerant type			R410A						
Throttle			EXV						
Design pressure(H/L)		MPa	4.4/2.6						
Refrigerant piping	Liquid side	mm	Φ6.35				Φ12.7		
	Gas side	mm	Φ12.7				Φ15.9		
Drainage water pipe dia.		mm	OD Φ25						
Controller			Wireless remote controller						

Note:

- Nominal cooling capacities are based on the following conditions: return air temperature : 80.6°F(27°C)DB,66.2°F(19°C)WB,and outdoor temperature: 95°F(35°C) DB,equivalent ref. piping: 26.25ft(8m) (horizontal) .
- Nominal heating capacities are based on the following conditions: return air temperature: 68°F(20°C)DB,outdoor temperature: 44.6°F(7°C)DB,42.8°F(6°C) WB, and equivalent ref. piping: 26.25ft (8m) (horizontal).
- Sound Level is measured 4.59ft.(1.4m) below the unit.

Specifications 50Hz

Model		40VZ006H11200011	40VZ007H11200011	40VZ009H11200011	40VZ012H11200011	40VZ016H11200011	40VZ020H11200011	40VZ024H11200011	
Power Supply		V-Ph-Hz	220-240V-1Ph-50Hz						
Cooling	Capacity	kW	1.8	2.2	2.8	3.6	4.5	5.6	7.1
		Btu/h	6100	7500	9600	12300	15400	19100	24200
	Input	W	41	41	41	41	48	48	60
	Rated current	A	0.24	0.24	0.25	0.25	0.27	0.32	0.36
Heating	Capacity	kW	2.2	2.6	3.2	4	5	6.3	8
		Btu/h	7500	8900	10900	13600	17100	21500	27300
	Input	W	41	41	41	41	43	44	55
	Rated current	A	0.24	0.24	0.25	0.25	0.27	0.32	0.36
Indoor air flow(H/M/L)		m³/h	523/404/275	523/404/275	573/456/315	573/456/315	693/600/476	792/688/549	933/749/592
		CFM	308/238/162	308/238/162	337/268/185	337/268/185	408/353/280	466/405/323	549/441/349
Indoor noise level(H/M/L)		dB(A)	37/34/30	38/34/30	39/37/34	40/38/34	41/39/35	42/40/36	44/41/37
Indoor unit	Dimension(WxHxD)	mm	1054×153×425				1204×189×443		
	Packing(WxHxD)	mm	1155×245×490				1370×295×505		
	Net/Gross weight	kg	12.5/16		13/16.5		18.5/23.2	18.8/23.5	19.5/24.2
Panel	Dimension(WxHxD)	mm	1180×25×465				1350×25×505		
	Packing(WxHxD)	mm	1232×107×517				1410×95×560		
	Net/Gross weight	kg	3.5/5.2				4/5.4		
Refrigerant type			R410A						
Throttle			EXV						
Design pressure(H/L)		MPa	4.4/2.6						
Refrigerant piping	Liquid side	mm	Φ6.35				Φ12.7		
	Gas side	mm	Φ12.7				Φ15.9		
Drainage water pipe dia.		mm	OD Φ25						
Controller			Wireless remote controller						

Note:

- Nominal cooling capacities are based on the following conditions: return air temperature : 80.6°F(27°C)DB,66.2°F(19°C)WB,and outdoor temperature: 95°F(35°C) DB,equivalent ref. piping: 26.25ft(8m) (horizontal) .
- Nominal heating capacities are based on the following conditions: return air temperature: 68°F(20°C)DB,outdoor temperature: 44.6°F(7°C)DB,42.8°F(6°C) WB, and equivalent ref. piping: 26.25ft (8m) (horizontal).
- Sound Level is measured 4.59ft.(1.4m) below the unit.

Two-way Cassette



-  Auto Restart
-  Auto Addressing
-  Follow Me
-  LED Display
-  Built-in Drain Pump
-  Fresh Air
-  Cleanable Panel
-  Anti-Cold Air Function

Quiet operation

Optimized airflow duct with low resistance makes noise level get reduced greatly, min. 24dB(A).

Stylish design and slim body

Thanks to the stylish appearance and slim body, the unit can be harmonious with the room decoration and ambient. Slim body with only 11-13/16in.(300mm) height needs small suspended ceiling space. Installation is free of story height limitation which makes the decoration much more flexible.

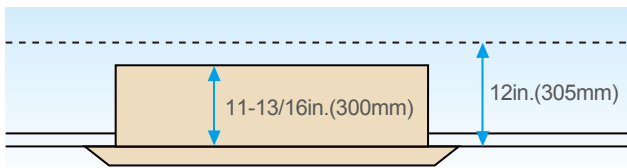

Standard built-in drain pump with 29-17/32in.(750mm) pump head (higher pumphead can be customized).

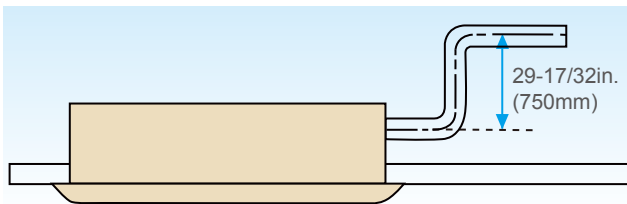

Flat-type suction grille design makes maintenance work very easy.

High airflow

High airflow for high ceiling application guarantees equal comfort of large space. It makes every customer of the room get even distribution of airflow and temperature.

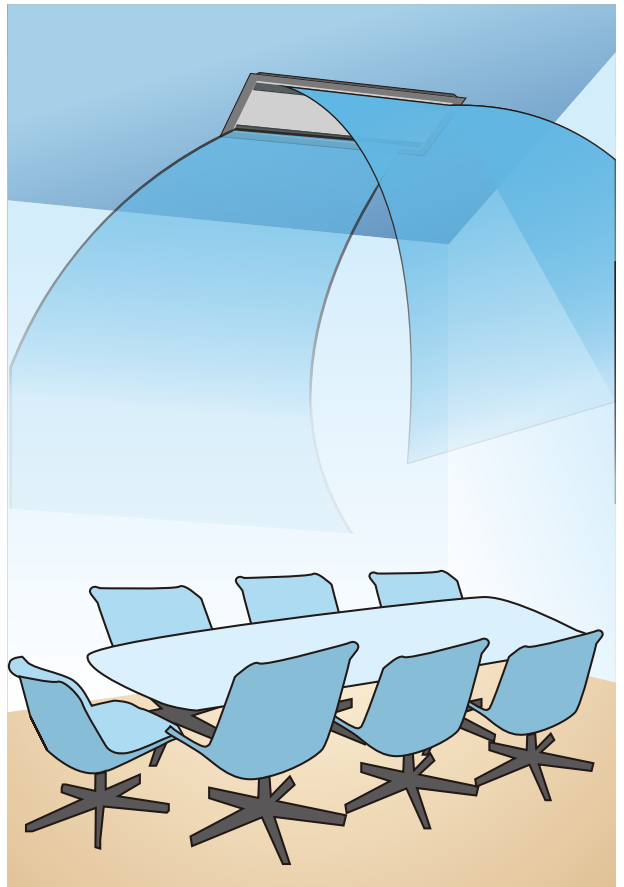

Specifications 60Hz

Model			40VT007H11300010	40VT009H11300010	40VT012H11300010	40VT016H11300010	40VT020H11300010	40VT024H11300010
Power supply		V-Ph-Hz	208-230V-1Ph-60Hz					
Cooling	Capacity	kW	2.2	2.8	3.6	4.5	5.6	7.1
		Btu/h	7500	9600	12300	15400	19100	24200
	Input	W	78	78	83	115	133	205
	Rated current	A	0.33	0.33	0.36	0.5	0.57	0.87
Heating	Capacity	kW	2.6	3.2	4	5	6.3	8
		Btu/h	8900	10900	13600	17100	21500	27300
	Input	W	78	78	83	115	133	205
	Rated current	A	0.33	0.33	0.36	0.5	0.57	0.87
Indoor air flow (H/M/L)		m ³ /h	674/509/381	674/509/381	740/577/435	878/689/561	941/776/654	1236/1110/864
		CFM	397/300/224	397/300/224	436/340/256	517/406/330	554/457/385	727/653/509
Indoor noise level (H/M/L)		dB(A)	33/29/24	36/32/29	36/32/29	39/35/30	39/35/30	44/40/34
Indoor unit	Dimension (WxHxD)	mm	1172×299×591	1172×299×591	1172×299×591	1172×299×591	1172×299×591	1172×299×591
	Packing (WxHxD)	mm	1355×400×675	1355×400×675	1355×400×675	1355×400×675	1355×400×675	1355×400×675
	Net/Gross weight	kg	34/42.5	34/42.5	34/42.5	36.5/45	36.5/45	36.5/45
Panel	Dimension (WxHxD)	mm	1430×53×680	1430×53×680	1430×53×680	1430×53×680	1430×53×680	1430×53×680
	Packing (WxHxD)	mm	1525×130×765	1525×130×765	1525×130×765	1525×130×765	1525×130×765	1525×130×765
	Net/Gross weight	(kg)	34/42.5	34/42.5	34/42.5	36/44.5	36/44.5	36/44.5
Throttle			EXV	EXV	EXV	EXV	EXV	EXV
Design pressure(H/ L)		MPa	4.4/2.6	4.4/2.6	4.4/2.6	4.4/2.6	4.4/2.6	4.4/2.6
Refrigerant piping	Liquid side	mm	Φ6.35	Φ6.35	Φ6.35	Φ6.35	Φ9.53	Φ9.53
	Gas side	mm	Φ12.7	Φ12.7	Φ12.7	Φ12.7	Φ15.9	Φ15.9
Drainage water pipe diameter		mm	ID Φ25, OD Φ32	ID Φ25, OD Φ32	ID Φ25, OD Φ32	ID Φ25, OD Φ32	ID Φ25, OD Φ32	ID Φ25, OD Φ32
Controller			Wireless remote controller					

Notes:

- Nominal cooling capacities are based on the following conditions: return air temperature : 80.6°F(27°C)DB,66.2°F(19°C)WB,and outdoor temperature: 95°F(35°C) DB,equivalent ref. piping: 26.25ft(8m) (horizontal) .
- Nominal heating capacities are based on the following conditions: return air temperature: 68°F(20°C)DB,outdoor temperature: 44.6°F(7°C)DB,42.8°F(6°C) WB, and equivalent ref. piping: 26.25ft (8m) (horizontal).
- Sound Level is measured 4.59ft.(1.4m) below the unit.

Specifications 50Hz

Model			40VT007H10200010	40VT009H10200010	40VT012H10200010	40VT016H10200010	40VT020H10200010	40VT024H10200010
Power supply		V-Ph-Hz	220-240V-1ph-50Hz					
Cooling	Capacity	kW	2.2	2.8	3.6	4.5	5.6	7.1
		BTU	7500	9600	12300	15400	19100	24200
	Input	W	65	65	65	97	112	153
	Rated current	A	0.35	0.45	0.45	0.55	0.55	0.75
Heating	Capacity	kW	2.6	3.2	4	5	6.3	8
		BTU	8900	10900	13600	17100	21500	27300
	Input	W	65	65	65	97	112	153
	Rated current	A	0.35	0.45	0.45	0.55	0.55	0.75
Indoor air flow (H/M/L)		m ³ /h	654/530/410	654/530/410	725/591/458	850/670/550	980/800/670	1200/1000/770
		CFM	385/312/241	385/312/241	427/348/270	7	577/471/394	706/589/453
Indoor noise level (Hi/Mid/Lo)		dB(A)	33/29/24	36/32/29	36/32/29	39/35/30	39/35/30	44/40/34
Indoor unit	Dimension (W×H×D)	mm	1172×300×592	1172×300×592	1172×300×592	1172×300×592	1172×300×592	1172×300×592
	Packing (W×H×D)	mm	1355×400×675	1355×400×675	1355×400×675	1355×400×675	1355×400×675	1355×400×675
	Net/Gross weight	kg	33/42	33/42	33/42	35/44	35/44	35/44
Panel	Dimension (W×H×D)	mm	1430×90×680	1430×90×680	1430×90×680	1430×90×680	1430×90×680	1430×90×680
	Packing (W×H×D)	mm	1525×130×765	1525×130×765	1525×130×765	1525×130×765	1525×130×765	1525×130×765
	Net/Gross weight	kg	10.5/15	10.5/15	10.5/15	10.5/15	10.5/15	10.5/15
Refrigerant type			R410A	R410A	R410A	R410A	R410A	R410A
Throttle			EXV					
Design pressure		MPa	4.4/2.6					
Refrigerant piping	Liquid side	mm	Φ6.35	Φ6.35	Φ6.35	Φ6.35	Φ9.53	Φ9.53
	Gas side	mm	Φ12.7	Φ12.7	Φ12.7	Φ12.7	Φ15.9	Φ15.9
Drainage water pipe dia.		mm	ID Φ25, OD Φ32					
Controller			Wireless controller					

Notes:

- Nominal cooling capacities are based on the following conditions: return air temperature : 80.6°F(27°C)DB,66.2°F(19°C)WB,and outdoor temperature: 95°F(35°C) DB,equivalent ref. piping: 26.25ft(8m) (horizontal) .
- Nominal heating capacities are based on the following conditions: return air temperature: 68°F(20°C)DB,outdoor temperature: 44.6°F(7°C)DB,42.8°F(6°C) WB, and equivalent ref. piping: 26.25ft (8m) (horizontal).
- Sound Level is measured 4.59ft.(1.4m) below the unit.

Compact Four-way Cassette



-  Auto Restart
-  Fresh Air
-  Auto Addressing
-  Cleanable Panel
-  Follow Me
-  Anti-Cold Air Function
-  Built-in Drain Pump
-  LED Display
-  Super High Air Flow

Compact design, easy installation and maintenance

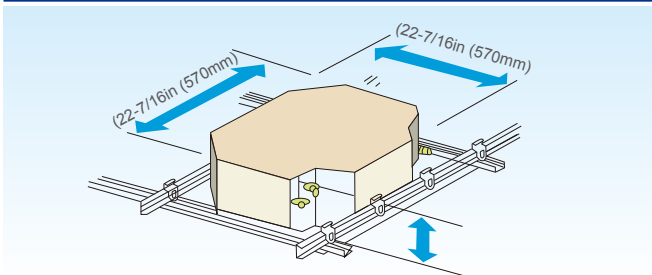

Extremely compact casing makes it perfectly match with the ambient decoration. Little space is required for installation into a shallow ceiling.

Due to its compact body and light weight, all models can be installed without a hoist.

Quiet operation, soft air supply

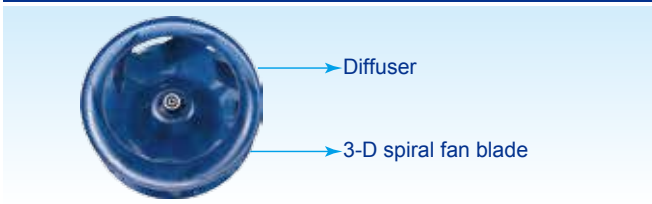

Streamline plate ensures quietness
Advanced 3-D spiral fan design reduces the air resistance and operation noise.

Uniform air flow of four ways

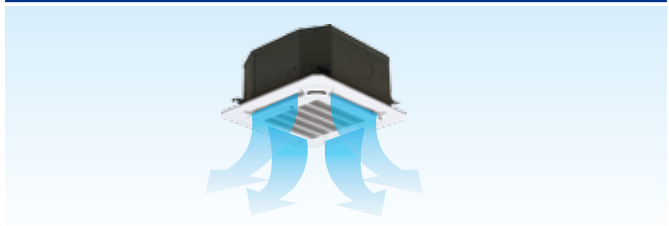

The four air discharge port provides strong circulating air flow to cool or heat every corner of the room and realizes even temperature distribution; by choosing high airflow mode, high ceiling application over 1/8in.(3m) can get equal comfort.

360° Airflow outlet



360°air outlet provides strong circulating air flow to cool or heat every corner of the room and realizes even temperature distribution.

Lift pump

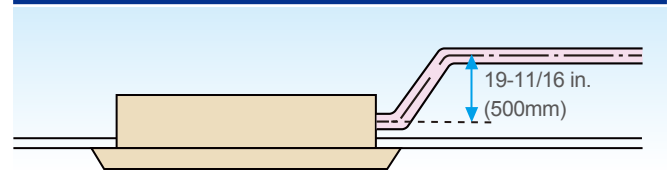

Drain up pump with 19-11/16 in.(500mm) pump head fitted as standard, max. up to 600mm pump head.

Specifications 60Hz

Model		40VX007H11300010	40VX009H11300010	40VX012H11300010	40VX016H11300010	40VX020H11300010	
Power supply		V-ph-Hz	208-230V-1Ph~60Hz				
Cooling	Capacity	kW	2.2	2.8	3.6	4.5	5.6
		Btu/h	7500	9600	12300	15400	19100
	Input	W	50	50	60	60	60
	Rated current	A	0.175	0.175	0.21	0.21	0.21
Heating	Capacity	kW	2.4	3.2	4	5	6.3
		Btu/h	8200	10900	13600	17100	21500
	Input	W	50	50	60	60	60
	Rated current	A	0.175	0.175	0.21	0.21	0.21
Indoor air flow (H/M/L)		m ³ /h	532/397/292/215	539/408/310/231	632/496/359/263	632/496/359/263	632/496/359/263
		CFM	313/234/172/127	317/240/182/136	372/292/211/155	372/292/211/155	372/292/211/155
Sound level (sound pressure)		dB(A)	35.8/33.4/23.4	35.8/33.4/23.4	41.5/35.6/28.8	41.5/35.6/28.8	41.5/35.6/28.8
Indoor unit	Dimension (W×H×D)	mm	570×265×570	570×265×570	570×265×570	570×265×570	570×265×570
	Packing (W×H×D)	mm	675×285×675	675×285×675	675×285×675	675×285×675	675×285×675
	Net/Gross weight	kg	16/20	16/20	18/22	18/22	18/22
Panel	Dimension (W×H×D)	mm	647×50×647	647×50×647	647×50×647	647×50×647	647×50×647
	Packing (W×H×D)	mm	715×113×715	715×113×715	715×113×715	715×113×715	715×113×715
	Net/Gross weight	lbs. (kg)	3/5	3/5	3/5	3/5	3/5
Refrigerant	Type		R410a	R410a	R410a	R410a	R410a
Throttle			Electric expansive valve				
Design pressure(H/L)		MPa	4.4/2.6	4.4/2.6	4.4/2.6	4.4/2.6	4.4/2.6
Refrigerant piping	Liquid side	mm	Φ6.35	Φ6.35	Φ6.35	Φ6.35	Φ6.35
	Gas side	mm	Φ12.7	Φ12.7	Φ12.7	Φ12.7	Φ12.7
Drainage water pipe diameter		mm	OD Φ25)	OD Φ25)	OD Φ25)	OD Φ25)	OD Φ25)
controller			Wireless remote controller				

Notes:

- Nominal cooling capacities are based on the following conditions: return air temperature : 80.6°F(27°C)DB,66.2°F(19°C)WB,and outdoor temperature: 95°F(35°C) DB, equivalent ref. piping: 26.25ft(8m) (horizontal) .
- Nominal heating capacities are based on the following conditions: return air temperature: 68°F(20°C)DB,outdoor temperature: 44.6°F(7°C)DB,42.8°F(6°C) WB, and equivalent ref. piping: 26.25ft (8m) (horizontal).
- Sound Level is measured 4.59ft.(1.4m) below the unit.

Specifications 50Hz

Model			40VX007H11200010	40VX009H11200010	40VX012H11200010	40VX016H11200010
Power supply		V-ph-Hz	220~240-1-50	220~240-1-50	220~240-1-50	220~240-1-50
Cooling	Capacity	kW	2.2	2.8	3.6	4.5
		BTU	9600	12300	15400	19100
	Input	W	50	50	58	58
	Rated current	A	0.175	0.175	0.21	0.21
Heating	Capacity	kW	2.4	3.2	4	5
		BTU	10900	13600	17100	21500
	Input	W	42	42	50	50
	Rated current	A	0.175	0.175	0.21	0.21
Indoor air flow (SH/Hi/Mi/Lo)		m ³ /h	522/414/313/238	522/414/313/238	610/521/409/314	610/521/409/314
		CFM	307/244/184/140	307/244/184/140	359/307/241/185	359/307/241/185
Sound level (sound pressure)		dB(A)	35.8/33.4/23.4	35.8/33.4/23.4	41.5/35.6/28.8	41.5/35.6/28.8
Indoor unit	Dimension (W×H×D)	mm	630×260×570	630×260×570	630×260×570	630×260×570
	Packing (W×H×D)	mm	675×285×675	675×285×675	675×285×675	675×285×675
	Net/Gross weight	Kg	16/20	16/20	18/22	18/22
Panel	Dimension (W×H×D)	mm	647×50×647	647×50×647	647×50×647	647×50×647
	Packing (W×H×D)	mm	715×123×715	715×123×715	715×123×715	715×123×715
	Net/Gross weight	Kg	2.5/4.5	2.5/4.5	2.5/4.5	2.5/4.5
Refrigerant Type			R410a	R410a	R410a	R410a
Design pressure		MPa	4.4/2.6	4.4/2.6	4.4/2.6	4.4/2.6
Refrigerant piping	Liquid side	mm	Φ6.35	Φ6.35	Φ6.35	Φ6.35
	Gas side	mm	Φ12.7	Φ12.7	Φ12.7	Φ12.7
Drainage water pipe dia.		mm	ODΦ25	ODΦ25	ODΦ25	ODΦ25
Wireless remote controller			Wirelesscontroller			

Notes:

- Nominal cooling capacities are based on the following conditions: return air temperature : 80.6°F(27°C)DB,66.2°F(19°C)WB,and outdoor temperature: 95°F(35°C) DB, equivalent ref. piping: 26.25ft(8m) (horizontal) .
- Nominal heating capacities are based on the following conditions: return air temperature: 68°F(20°C)DB,outdoor temperature: 44.6°F(7°C)DB,42.8°F(6°C) WB, and equivalent ref. piping: 26.25ft (8m) (horizontal).
- Sound Level is measured 4.59ft.(1.4m) below the unit.

Standard Four-way Cassette Type



-  Auto Restart
-  Auto Addressing
-  Follow Me
-  Built-in Drain Pump
-  Super High Air Flow
-  Fresh Air
-  Cleanable Panel
-  Anti-Cold Air Function
-  LED Display

Lower operating sound

The new designed wind wheel, ring and the built-in throttling part make the noise reduced greatly.



The former wind wheel

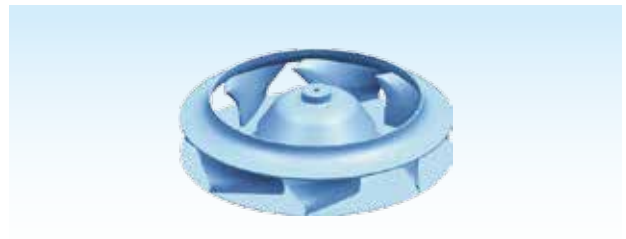

Optimized wind wheel

More reliable

- The connection of drainage pan adopts foaming technology which can further improve the connection tightness.
- Capacitor is isolated by sheet metal box making more safety and higher reliability.



- The strong and weak electricity wires are separated in electronic control box making the interference decreased greatly.

Flexible air distribution type

- 7 discharge patterns in 2 to 4 directions can be selected to suit the requirements of installation site or the shape of the room.

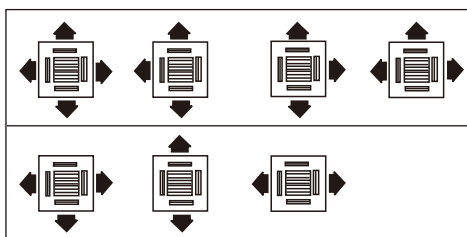

- Duct connection is possible.

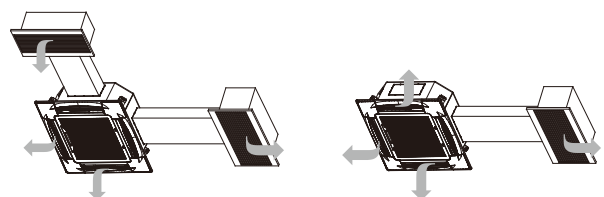

Specifications 60Hz

Model			40VK009H11300011	40VK012H11300011	40VK016H11300011	40VK020H11300011	40VK024H11300011
Power supply			208-230V-1Ph~60Hz				
Cooling	Capacity	kW	2.8	3.6	4.5	5.6	7.1
		Btu/h		12283	15354	19107	24225
	Power input	W	80	80	88	88	105
	Rated Current	A	0.36	0.36	0.39	0.39	0.47
Heating	Capacity	kW	3.2	4.0	5.0	6.3	8.0
		Btu/h	10918	13648	17060	21496	27296
	Power input	W	80	80	88	88	105
	Rated Current	A	0.36	0.36	0.39	0.39	0.47
Indoor air flow (H/M/L)		m ³ /h	791/674/596	791/674/596	942/777/662	942/777/662	1235/1013/805
		CFM	465/396/351	465/396/351	554/457/389	554/457/389	726/596/474
Sound pressure level (H/M/L)		dB(A)	30/25/22	30/25/22	35/31/27	35/31/27	43/37/31
Indoor Unit	Net dimension (W×H×D)	mm	840×230×840	840×230×840	840×230×840	840×230×840	840×230×840
	Packing size (W×H×D)	mm	955×260×955	955×260×955	955×260×955	955×260×955	955×260×955
	Net/Gross weight	kg	21.5/26.7	21.5/26.7	23.7/28.9	23.7/28.9	23.7/28.9
Panel	Net dimension (W×H×D)	mm	950×46×950	950×46×950	950×46×950	950×46×950	950×46×950
	Packing size (W×H×D)	mm	1035×90×1035	1035×90×1035	1035×90×1035	1035×90×1035	1035×90×1035
	Net/Gross weight	kg	6/9	6/9	6/9	6/9	6/9
Refrigerant type			R410A	R410A	R410A	R410A	R410A
Throttle type		Type	EXV	EXV	EXV	EXV	EXV
Design pressure (H/L)		MPa	4.4/2.6	4.4/2.6	4.4/2.6	4.4/2.6	4.4/2.6
Pipe connections	Liquid pipe	mm	Φ6.35	Φ6.35	Φ6.35	Φ9.53	Φ9.53
	Gas pipe	mm	Φ12.7	Φ12.7	Φ12.7	Φ15.9	Φ15.9
	Drain pipe	mm	OD Φ32	OD Φ32	OD Φ32	OD Φ32	OD Φ32
Controller			Wireless remote controller				

Model			40VK028H11300011	40VK030H11300011	40VK034H11300011	40VK036H11300011	40VK048H11300011
Power supply			208-230V-1Ph~60Hz				
Cooling	Capacity	kW	8.0	9.0	10.0	11.2	14.0
		Btu/h	27296	30708	34120	38214	47768
	Power input	W	120	187	200	200	220
	Rated Current	A	0.53	0.83	0.89	0.89	0.98
Heating	Capacity	kW	9.0	10.0	11.1	12.5	16.0
		Btu/h	30708	34120	37873	42650	54592
	Power input	W	120	187	200	200	220
	Rated Current	A	0.53	0.83	0.89	0.89	0.98
Indoor air flow (H/M/L)		m ³ /h	1235/1013/805	1333/1158/957	1634/1219/1139	1634/1219/1139	1692/1243/1157
		CFM	726/596/474	784/681/563	961/717/670	961/717/670	995/731/681
Sound pressure level (H/M/L)		dB(A)	43/37/31	43/38/32	45/37/35	45/37/35	46/38/37
Indoor Unit	Net dimension (W×H×D)	mm	840×230×840	840×300×840	840×300×840	840×300×840	840×300×840
	Packing size (W×H×D)	mm	955×260×955	955×330×955	955×330×955	955×330×955	955×330×955
	Net/Gross weight	kg	23.7/28.9	28.7/34.1	28.7/34.1	28.7/34.1	30.9/36.3
Panel	Net dimension (W×H×D)	mm	950×46×950	950×46×950	950×46×950	950×46×950	950×46×950
	Packing size (W×H×D)	mm	1035×90×1035	1035×90×1035	1035×90×1035	1035×90×1035	1035×90×1035
	Net/Gross weight	kg	6/9	6/9	6/9	6/9	6/9
Refrigerant type			R410A	R410A	R410A	R410A	R410A
Throttle type		Type	EXV	EXV	EXV	EXV	EXV
Design pressure (H/L)		MPa	4.4/2.6	4.4/2.6	4.4/2.6	4.4/2.6	4.4/2.6
Pipe connections	Liquid pipe	mm	Φ9.53	Φ9.53	Φ9.53	Φ9.53	Φ9.53
	Gas pipe	mm	Φ15.9	Φ15.9	Φ15.9	Φ15.9	Φ15.9
	Drain pipe	mm	OD Φ32	OD Φ32	OD Φ32	OD Φ32	OD Φ32
Controller			Wireless remote controller				

Notes:

- Nominal cooling capacities are based on the following conditions: return air temperature : 80.6°F(27°C)DB,66.2°F(19°C)WB,and outdoor temperature: 95°F(35°C)DB, equivalent ref. piping: 26.25ft. (8m) (horizontal).
- Nominal heating capacities are based on the following conditions: return air temperature: 68°F(20°C)DB,outdoor temperature: 44.6°F(7°C)DB,42.8°F(6°C)WB, and equivalent ref. Piping: 26.25ft. (8m) (horizontal).
- Sound Level is measured 4.59ft. (1.4m) below the unit.

* Specifications are subject to change without prior notice for product improvement.

Specifications 50Hz

Model			40VK009H11200011	40VK012H11200011	40VK016H11200011	40VK020H11200011	40VK024H11200011
Power supply		V-Ph-Hz	220-240V, 1Ph, 50Hz				
Cooling	Capacity	kW	2.8	3.6	4.5	5.6	7.1
		BTU	9600	12300	15400	19100	24200
	Input	W	80	80	90	90	90
	Rated current	A	0.4	0.4	0.4	0.4	0.5
Heating	Capacity	kW	3.2	4	5	6.3	8
		BTU	10900	13600	17100	21500	27300
	Input	W	80	80	90	90	90
	Rated current	A	0.4	0.4	0.4	0.4	0.5
Indoor air flow (SH/H/M/L)		m ³ /h	920/764/638/554	920/764/638/554	1090/905/740/651	1090/905/740/651	1140/950/767/663
		CFM	541/450/375/326	541/450/375/326	641/532/435/383	641/532/435/383	670/560/451/390
Indoor noise level (Hi/Mid/Lo)		dB(A)	32/31/30	32/31/30	36/34/33	36/34/33	38/36/35
Indoor unit	Dimension (W×H×D)	mm	840×230×840	840×230×840	840×230×840	840×230×840	840×230×840
	Packing (W×H×D)	mm	955×260×955	955×260×955	955×260×955	955×260×955	955×260×955
	Net/Gross weight	kg	21.5/26.7	21.5/26.7	23.7/28.9	23.7/28.9	23.7/28.9
Panel	Dimension (W×H×D)	mm	950×46×950	950×46×950	950×46×950	950×46×950	950×46×950
	Packing (W×H×D)	mm	1035×90×1035	1035×90×1035	1035×90×1035	1035×90×1035	1035×90×1035
	Net/Gross weight	kg	6/9	6/9	6/9	6/9	6/9
Refrigerant type			R410A	R410A	R410A	R410A	R410A
Throttle		Type	EXV	EXV	EXV	EXV	EXV
Design pressure		MPa	4.4/2.6	4.4/2.6	4.4/2.6	4.4/2.6	4.4/2.6
Refrigerant piping	Liquid side/	mm	Φ6.35	Φ6.35	Φ6.35	Φ9.53	Φ9.53
	Gas side	mm	Φ12.7	Φ12.7	Φ12.7	Φ15.9	Φ15.9
Drainage water pipe dia.		mm	ODΦ32	ODΦ32	ODΦ32	ODΦ32	ODΦ32
Controller			Wireless controller	Wireless controller	Wireless controller	Wireless controller	Wireless controller

Model			40VK028H11200011	40VK030H11200011	40VK034H11200011	40VK036H11200011	40VK048H11200011
Power supply		V-Ph-Hz	220-240V, 1Ph, 50Hz				
Cooling	Capacity	kW	8	9	10	11.2	14
		BTU	27300	30700	34100	38200	47800
	Input	W	97	155	155	155	180
	Rated current	A	0.5	0.7	0.7	0.7	0.8
Heating	Capacity	kW	9	10	11	12.5	15
		BTU	30700	34100	37500	42700	51200
	Input	W	97	155	155	155	180
	Rated current	A	0.5	0.7	0.7	0.7	0.8
Indoor air flow (SH/H/M/L)		m ³ /h	1380/1200/1021/789	1598/1332/1129/908	1750/1651/1304/1127	1750/1651/1304/1127	1774/1658/1335/1130
		CFM	812/706/600/464	940/784/664/534	1029/971/767/663	1029/971/767/663	1044/975/785/665
Indoor noise level (Hi/Mid/Lo)		dB(A)	42/39/37	43/39/38	45/42/40	45/42/40	46/41/39
Indoor unit	Dimension (W×H×D)	mm	840×230×840	840×300×840	840×300×840	840×300×840	840×300×840
	Packing (W×H×D)	mm	955×260×955	955×330×955	955×330×955	955×330×955	955×330×955
	Net/Gross weight	kg	23.7/28.9	28.7/34.1	28.7/34.1	28.7/34.1	30.9/36.3
Panel	Dimension (W×H×D)	mm	950×46×950	950×46×950	950×46×950	950×46×950	950×46×950
	Packing (W×H×D)	mm	1035×90×1035	1035×90×1035	1035×90×1035	1035×90×1035	1035×90×1035
	Net/Gross weight	kg	6/9	6/9	6/9	6/9	6/9
Refrigerant type			R410A	R410A	R410A	R410A	R410A
Throttle		Type	EXV	EXV	EXV	EXV	EXV
Design pressure		MPa	4.4/2.6	4.4/2.6	4.4/2.6	4.4/2.6	4.4/2.6
Refrigerant piping	Liquid side/	mm	Φ9.53	Φ9.53	Φ9.53	Φ9.53	Φ9.53
	Gas side	mm	Φ15.9	Φ15.9	Φ15.9	Φ15.9	Φ15.9
Drainage water pipe dia.		mm	ODΦ32	ODΦ32	ODΦ32	ODΦ32	ODΦ32
Controller			Wireless controller	Wireless controller	Wireless controller	Wireless controller	Wireless controller







Notes:

- Nominal cooling capacities are based on the following conditions: return air temperature : 80.6°F(27°C)DB,66.2°F(19°C)WB,and outdoor temperature: 95°F(35°C)DB, equivalent ref. piping: 26.25ft. (8m) (horizontal).
- Nominal heating capacities are based on the following conditions: return air temperature: 68°F(20°C)DB,outdoor temperature: 44.6°F(7°C)DB,42.8°F(6°C)WB, and equivalent ref. Piping: 26.25ft. (8m) (horizontal).
- Sound Level is measured 4.59ft. (1.4m) below the unit.

* Specifications are subject to change without prior notice for product improvement.

Low Static Pressure Duct



-  Auto Restart
-  Auto Addressing
-  Follow Me
-  Wireless remote controller
-  Anti-Cold Air Function
-  Super High Air Flow

Low sound level



Utilizes the centrifugal type blower, provides a minimum noise level of 24dB (A), an excellent choice for hotels and other sound-sensitive places.

V shape evaporator-- good for heat exchanging

V shape evaporator design enhances heat exchanging efficiency about 22%.

Convenient for installation and maintenance

The EXV is fixed inside the indoor unit.

Compact design

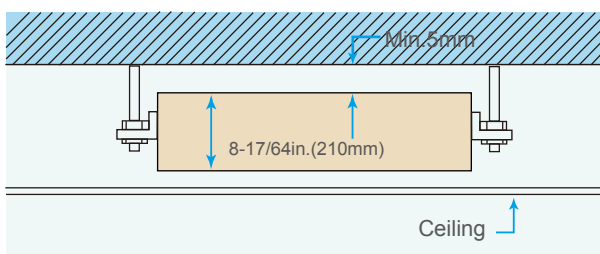

Uniform 8-17/64in.(210mm) in height, compact design for easy locate where space ceiling is limited, The whole body adopts fireproof plastic material, the minimum weight is 30.9lbs(14kg).

Options

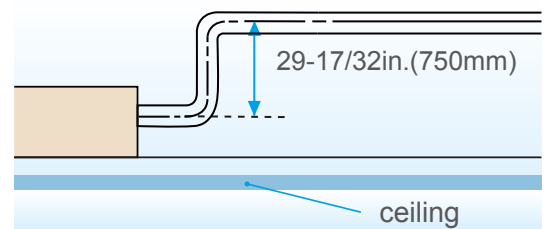

A drain pump with 29-17/32in.(750mm) pumphead is an optional accessory.

Specifications 60Hz

Model		42VD006H113002011	42VD007H113002011	42VD009H113002011	42VD012H113002011	
Power supply		V- Ph-Hz	208-230V~, 1Ph, 60Hz			
Cooling	Capacity	kW	1.8	2.2	2.8	3.6
		Btu/h	6100	7500	9600	12300
	Input	W	59	59	59	65
	Rated current	A	0.26	0.26	0.26	0.3
Heating	Capacity	kW	2.2	2.6	3.2	4
		Btu/h	7500	8900	10900	13600
	Input	W	59	59	59	65
	Rated current	A	0.26	0.26	0.26	0.3
Indoor air flow (SH/H/M/L)		m ³ /h	606/578/512/409			646/617/551/441
		CFM	357/340/301/241			380/363/324/260
Indoor external static pressure		Pa	10(10-30)	10(10-30)	10(10-30)	10(10~30)
Indoor noise level (H/M/L)		dB(A)	35/27/24	35/27/24	35/27/24	38/32/28
Indoor unit	Dimension (W×H×D)	in.(mm)	740×210×470	740×210×470	740×210×470	740×210×470
	Packing (W×H×D)	in.(mm)	910×230×510	910×230×510	910×230×510	910×230×510
	Net/Gross weight	kg	14.5/18	14.5/18	14.5/18	14.5/18
Refrigerant type			R410A	R410A	R410A	R410A
Throttle		Type	EXV	EXV	EXV	EXV
Design pressure(H/L)		MPa	4.4/2.6	4.4/2.6	4.4/2.6	4.4/2.6
Refrigerant piping	Liquid side	mm	Φ6.35	Φ6.35	Φ6.35	Φ6.35
	Gas side	mm	Φ12.7	Φ12.7	Φ12.7	Φ12.7
Drainage water pipe diameter		mm	OD Φ25	OD Φ25	OD Φ25	OD Φ25
Controller			Wireless remote controller			

Model		42VD016H113002011	42VD020H113002011	42VD024H113002011	
Power supply		V- Ph-Hz	208-230V~, 1Ph, 60Hz		
Cooling	Capacity	kW	4.5	5.6	7.1
		Btu/h	15400	19100	24200
	Input	W	105	105	130
	Rated current	A	0.5	0.5	0.6
Heating	Capacity	kW	5	6.3	8
		Btu/h	17100	21500	27300
	Input	W	105	105	130
	Rated current	A	0.5	0.5	0.6
Indoor air flow (SH/H/M/L)		m ³ /h	803/824/690/609		1207/1060/970/811
		CFM	473/485/406/358		710/624/571/477
Indoor external static pressure		Pa	10(10~30)	10(10~30)	10(10~30)
Indoor noise level (H/M/L)		dB(A)	39/32/29	39/32/29	41/33/30
Indoor unit	Dimension (W×H×D)	in.(mm)	960×210×470		1180×210×470
	Packing (W×H×D)	in.(mm)	1130×230×510		1350×230×510
	Net/Gross weight	kg	18/22.5		22.5/26.5
Refrigerant type			R410A	R410A	R410A
Throttle		Type	EXV	EXV	EXV
Design pressure(H/L)		MPa	4.4/2.6	4.4/2.6	4.4/2.6
Refrigerant piping	Liquid side	mm	Φ6.35	Φ9.53	Φ9.53
	Gas side	mm	Φ12.7	Φ15.9	Φ15.9
Drainage water pipe diameter		mm	OD Φ25	OD Φ25	OD Φ25
Controller			Wireless remote controller		

Notes:

- Nominal cooling capacities are based on the following conditions: return air temp.: 27°CDB, 19°CWB, and outdoor temp.:35°CDB, equivalent ref. piping: 8m (horizontal).
 - Nominal heating capacities are based on the following conditions: return air temp.: 20°CDB, outdoor temp.: 7°CDB, 6°CWB, and equivalent ref. Piping: 8m (horizontal).
 - Sound level is measured at 1.4m below the air outlet.
- * External static pressure is based on high speed indoor air flow.

Specifications 50Hz



Model		42VD006H112002011	42VD007H112002011	42VD009H112002011	42VD012H112002011	42VD016H112002011	42VD020H112002011	42VD024H112002011		
Power supply		V-Hz-Ph	220-240V, 1Ph, 50Hz							
Cooling	Capacity	kW	1.8	2.2	2.8	3.6	4.5	5.6	7.1	
	Input	W	65	65	65	67	85	85	108	
	Rated Current	W	0.28	0.28	0.28	0.29	0.37	0.37	0.48	
Heating	Capacity	kW	2.2	2.6	3.2	4.0	5.0	6.3	8.0	
	Input	W	67	67	67	70	86	86	110	
	Rated Current	W	0.29	0.29	0.29	0.31	0.38	0.38	0.49	
Indoor air flow (SH/H/M/L)		m ³ /h	606/578/512/409	606/578/512/409	606/578/512/409	646/617/551/441	803/824/690/609	803/824/690/609	1207/1060/970/811	
		CFM	357/340/301/241	357/340/301/241	357/340/301/241	380/363/324/260	473/485/406/358	473/485/406/358	710/624/571/477	
Indoor external static pressure (H)		Pa	10(10-30)	10(10-30)	10(10~30)	10(10~30)	10(10~30)	10(10~30)	10(10~30)	
Indoor noise level (H/M/L)		dB(A)	35/27/24	35/27/24	35/27/24	35/27/24	39/32/29	39/32/29	41/33/30	
Indoor unit		Dimension (W×H×D)	740×210×470				960×210×470		1180×210×470	
		Packing (W×H×D)	910×230×510				1130×230×510		1350×230×510	
		Net/Gross weight	kg	14/17.5	14/17.5	14/17.5	14/17.5	18/22.5	18/22.5	21.5/26.5
Refrigerant type		R410A								
Throttle		Type	EXV							
Design pressure(H/L)		MPa	4.4/2.6							
Refrigerant piping		Liquid side	mm	Φ6.35	Φ6.35	Φ6.35	Φ6.35	Φ6.35	Φ6.35	Φ6.35
		Gas side	mm	Φ12.7	Φ12.7	Φ12.7	Φ12.7	Φ12.7	Φ12.7	Φ12.7
Drainage water pipe diameter		ODΦ25								
Controller		Wireless controller								

Notes:

- Nominal cooling capacities are based on the following conditions: return air temp.: 27°CDB, 19°CWB, and outdoor temp.:35°CDB, equivalent ref. piping: 8m (horizontal).
 - Nominal heating capacities are based on the following conditions: return air temp.: 20°CDB, outdoor temp.: 7°CDB, 6°CWB, and equivalent ref. Piping: 8m (horizontal).
 - Sound level is measured at 1.4m below the air outlet.
- * External static pressure is based on high speed indoor air flow.
 * Specifications are subject to change without prior notice for product improvement.

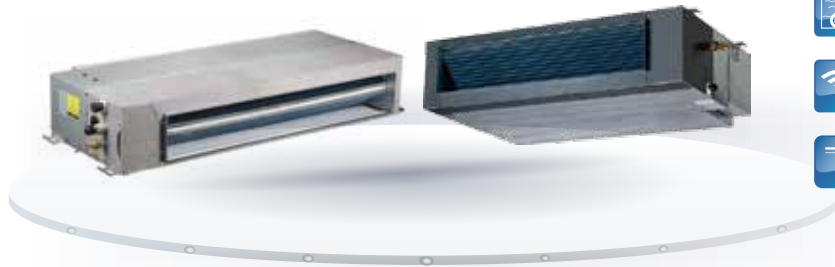
Concealed Duct Unit (A5 Type)



-  Auto Restart
-  Follow Me
-  Built-in Drain Pump
-  Auto Addressing
-  Connectable To Duct
-  Fresh Air
-  Anti-Cold Air Function
-  Wireless remote controller
-  Super High Air Flow

Compact size

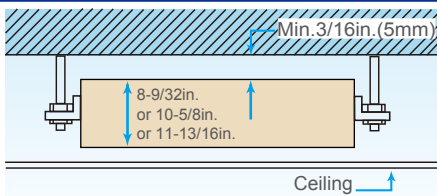

Only 8-9/32in.(210mm) (22~71 models) or 10-5/8in. (270mm) (80 to 112 models) or 11-13/16in.(300mm) (140 model) in height.

External static pressure

Four speed fan motor (Super high speed as an optional)

Change the wiring connection from 'SH' to 'H' to change the ESP.

Convenient installation

The EXV is fixed inside of the indoor unit.
 Standard filter placed in an aluminum frame, which is removable downward from bottom.
 Suction chamber is included as standard equipment.
 Fresh air hole, air inlet/outlet flange are standard for easy duct connection.
 Air inlet from back is standard and from bottom as optional with the same connectable duct.

Air intake from back

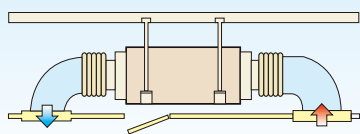

Air intake from below

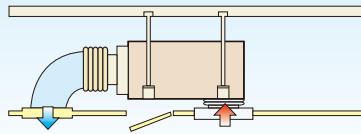

drain pump as standard

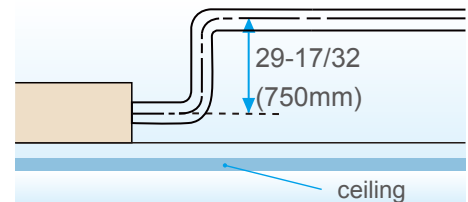

Flexible control and convenient for maintenance

Standard wireless remote controller WL-12-CM.
 The Electrical control box can be removed 1m away from the unit, easy to access when needs maintenance. (Should be required by client in advance and done by Carrier in factory).
 Standard functional port such as Remote On/Off Dry contact switch and Alarm signal output (220V).

Specifications 60Hz

Model			42VD007H113003011	42VD009H113003011	42VD012H113003011	42VD016H113003011	42VD020H113003011
Power supply		V- Ph-Hz	208-230V~,1Ph, 60Hz				
Cooling	Capacity	kW	2.2	2.8	3.6	4.5	5.6
		Btu/h	7500	9600	12300	15400	19100
	Input	W	66	72	77	100	100
	Rated current	A	0.24	0.24	0.28	0.48	0.48
Heating	Capacity	kW	2.6	3.2	4	5	6.3
		Btu/h	8900	10900	13600	17100	21500
	Input	W	66	72	77	100	100
	Rated current	A	0.24	0.24	0.28	0.48	0.48
Indoor air flow (SH/H/M/L)		m ³ /h	588(30pa)/538/456/375	588/538/456/375	614/597/514/429	763/811/684/575	763/811/684/575
		CFM	346/317/268/221	346/317/268/221	361/351/303/253	449/477/403/338	449/477/403/338
Indoor external static pressure (H)		Pa	10(10~30)	10(10~30)	10(10~30)	10(10~30)	10(10~30)
Indoor noise level (H/M/L)		dB(A)	36/35/32	37/35/32	38.6/37.5/33.8	39/37.9/34	39/37.9/34
Indoor unit	Dimension (W×H×D)	mm	740x210x500	740x210x500	740x210x500	960x210x500	960x210x500
	Packing (W×H×D)	mm	870×285×525	870×285×525	870×285×525	1115×285×525	1115×285×525
	Net/Gross weight	kg	17.5/20			22.5/26	22.5/26
Fresh Air intake hole diameter		mm	(Φ92)	Φ92	Φ92	Φ92	Φ92
Refrigerant type			R410A				
Throttle		Type	EXV				
Design pressure(H/L)		MPa	4.4/2.6				
Refrigerant piping	Liquid	mm	Φ6.35	Φ6.35	Φ6.35	Φ6.35	Φ9.53
	Gas	mm	Φ12.7	Φ12.7	Φ12.7	Φ12.7	Φ15.9
Drainage water pipe diameter		mm	OD Φ25				
Controller			Wireless remote controller				

Model			42VD024H113003011	42VD028H113003010	42VD030H113003010	42VD036H113003010	42VD048H113003010
Power supply		V- Ph-Hz	208-230V~,1Ph, 60Hz				
Cooling	Capacity	kW	7.1	8	9	11.2	14
		Btu/h	24200	27300	30700	38200	47800
	Input	W	125	133	134	378	352
	Rated current	A	0.6	1	1	1.8	1.55
Heating	Capacity	kW	8	9	10	12.5	15.5
		Btu/h	27300	30700	34100	42650	52900
	Input	W	125	133	134	378	352
	Rated current	A	0.6	1	1	1.8	1.55
Indoor air flow (SH/H/M/L)		m ³ /h	1127/1029/934/781	1388/1345/1165/1013	1388/1345/1165/1013	1851/1800/1556/1400	1745/1905/1636/1400
		CFM	663/606/550/460	817/792/686/596	817/792/686/596	1089/1059/916/824	1027/1121/963/824
Indoor external static pressure (H)		Pa	10(10~30)	20(10~50)	20(10~50)	40(10~80)	40(10~100)
Indoor noise level (H/M/L)		dB(A)	41.4/39/35	45.4/39.8/37	45.4/39.8/37	48.0/41.9/38	47.7/43.2/39.0
Indoor unit	Dimension (W×H×D)	mm	1180x210x500	1180×270×775	1180×270×775	1180×270×775	1240×300×865
	Packing (W×H×D)	mm	1335×285×525	1355×350×795	1355×350×795	1355×350×795	1400×375×925
	Net/Gross weight	kg	28/31.5	38/46.5	40/48	40/48	49/58
Fresh Air intake hole diameter		mm	Φ92	Φ125	Φ125	Φ125	Φ125
Refrigerant type			R410A				
Throttle		Type	EXV				
Design pressure(H/L)		MPa	4.4/2.6				
Refrigerant piping	Liquid	mm	Φ9.53	Φ9.53	Φ9.53	Φ9.53	Φ9.53
	Gas	mm	Φ15.9	Φ15.9	Φ15.9	Φ15.9	Φ15.9
Drainage water pipe diameter		mm	OD Φ25				
Controller			Wireless remote controller				

Notes:

- Nominal cooling capacities are based on the following conditions: return air temperature: 80.6°F(27°C)DB,66.2°F(19°C)WB,and outdoor temperature: 95°F(35°C)DB,equivalent ref. piping: 26.25ft. (8m) (horizontal).
 - Nominal heating capacities are based on the following conditions: return air temperature: 68°F(20°C)DB, outdoor temperature: 44.6°F(7°C)DB,42.8°F(6°C)WB, and equivalent ref. piping: 26.25ft. (8m) (horizontal).
 - Sound Level is measured 4.59ft. (1.4m) below the unit.
- * external static pressure are based on high speed indoor airflow.
 * Specifications are subject to change without prior notice for product improvement.

Specifications 50Hz

Model		42VD007H112013011	42VD009H112013011	42VD012H112013011	42VD016H112013011	42VD020H112013011	42VD024H112013011	
Power supply		V-ph-Hz 220-240V, 1Ph, 50Hz						
Cooling	Capacity	kW	2.2	2.8	3.6	4.5	5.6	7.1
		BTU	7500	9600	12300	15400	19100	24200
	Input	W	68	68	72	80	80	105
	Rated current	A	0.36	0.36	0.39	0.43	0.43	0.56
Heating	Capacity	kW	2.6	3.2	4	5	6.3	8.0
		BTU	8900	10900	13600	17100	21500	27300
	Input	W	65	65	69	80	80	105
	Rated current	A	0.36	0.36	0.39	0.43	0.43	0.56
Indoor air flow (/Hi/Mi/Lo)		m³/h	588/538/456/375	588/538/456/375	614/597/514/429	763/811/684/575	763/811/684/575	1127/1029/934/781
		CFM	346/317/268/221	346/317/268/221	361/351/303/253	449/477/403/338	449/477/403/338	663/606/550/460
Static pressure (Min.~Max.)		Pa	10(10~30)	10(10~30)	10(10~30)	10(10~30)	10(10~30)	10(10~30)
Sound level (sound pressure)		dB(A)	36/35/32	37/35/32	38.6/37.5/33.8	39/37.9/34	39/37.9/34	41.4/39/35
Indoor unit	Dimension (W×H×D)	mm	740*210*500			960*210*500		1180*210*500
	Packing (W×H×D)	mm	870*285*525			1115*285*525		1335*285*525
	Net/Gross weight	kg	17.5/21	17.5/21	17.5/21	22.5/26	22.5/26	28/31.5
Fresh Air Intake	Size (round)	mm	Φ92	Φ92	Φ92	Φ92	Φ92	Φ92
Refrigerant Type		R410A						
Throttle		Type	EXV					
Design pressure		MPa	4.4/2.6					
Refrigerant piping	Liquid side	mm	Φ6.35	Φ6.35	Φ6.35	Φ6.35	Φ9.53	Φ9.53
	Gas side	mm	Φ12.7	Φ12.7	Φ12.7	Φ12.7	Φ15.9	Φ15.9
Drainage water pipe diameter		mm	OD Φ25					
Controller		Wireless controller						

Model		42VD028H112003010	42VD030H112003010	42VD034H112003010	42VD036H112003010	42VD042H112003010	42VD048H112003010	
Power supply		V-ph-Hz 220-240V, 1Ph, 50Hz						
Cooling	Capacity	kW	8	9	10	11.2	12.5	14
		BTU	27300	30700	38200	47800		
	Input	W	231	231	327	327	355	355
	Rated current	A	1	1	1.8	1.8	1.9	1.9
Heating	Capacity	kW	9	10	11	12.5	13.5	15.5
		BTU	30700	34100	42650	52900		
	Input	W	231	231	327	327	355	355
	Rated current	A	1	1	1.8	1.8	1.9	1.9
Indoor air flow (/Hi/Mi/Lo)		m³/h	1388/1345/1165/1013	1388/1345/1165/1013	1851/1800/1556/1400	1851/1800/1556/1400	1745/1905/1636/1400	1745/1905/1636/1400
		CFM	817/792/686/596	817/792/686/596	1089/1059/916/824	1089/1059/916/824	1027/1121/963/824	1027/1121/963/824
Static pressure (Min.~Max.)		Pa	20(10~50)	20(10~50)	40(10~80)	40(10~80)	40(10~100)	40(10~100)
Sound level (sound pressure)		dB(A)	45.4/39.8/37	45.4/39.8/37	48.0 /41.9/38	48.0 /41.9/38	47.7/43.2/39.0	47.7/43.2/39.0
Indoor unit	Dimension (W×H×D)	mm	1140×270×775			1200×300×865		
	Packing (W×H×D)	mm	1355×350×795			1400×370×925		
	Net/Gross weight	kg	38/46.5	40/48	40/48	40/48	49/58	49/58
Fresh Air Intake	Size (round)	mm	Φ125	Φ125	Φ125	Φ125	Φ125	Φ125
Refrigerant Type		R410A						
Throttle		Type	EXV					
Design pressure		MPa	4.4/2.6					
Refrigerant piping	Liquid side	mm	Φ9.53	Φ9.53	Φ9.53	Φ9.53	Φ9.53	Φ9.53
	Gas side	mm	Φ15.9	Φ15.9	Φ15.9	Φ15.9	Φ15.9	Φ15.9
Drainage water pipe diameter		mm	ODΦ32					
Controller		Wireless controller						

Notes:

1. Nominal cooling capacities are based on the following conditions: return air temperature: 80.6°F(27°C)DB,66.2°F(19°C)WB,and outdoor temperature: 95°F(35°C)DB,equivalent ref. piping: 26.25ft. (8m) (horizontal).

2. Nominal heating capacities are based on the following conditions: return air temperature: 68°F(20°C)DB, outdoor temperature: 44.6°F(7°C)DB,42.8°F(6°C)WB, and equivalent ref. piping: 26.25ft. (8m) (horizontal).

3. Sound Level is measured 4.59ft. (1.4m) below the unit.

* external static pressure are based on high speed indoor airflow.

* Specifications are subject to change without prior notice for product improvement.

High Static Pressure Duct

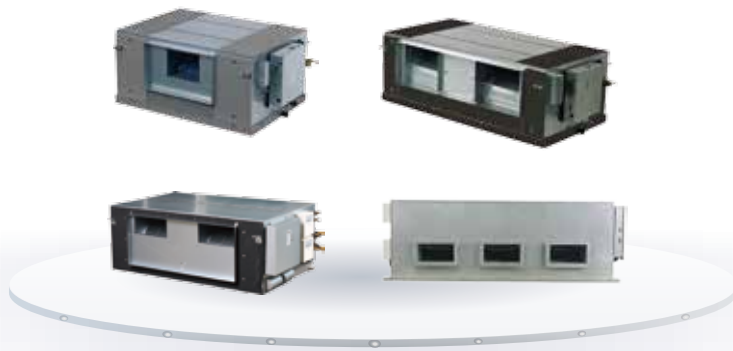

- Auto Restart
- Auto Addressing
- Follow Me
- Anti-Cold Air Function
- Connectable To Duct
- Wireless remote controller

Flexible duct design

Four speed fan motor (medium high speed as an option only for 71~160 model)
 External static pressure can be up to 196Pa (71~160 models) or 280Pa (200~450 models).

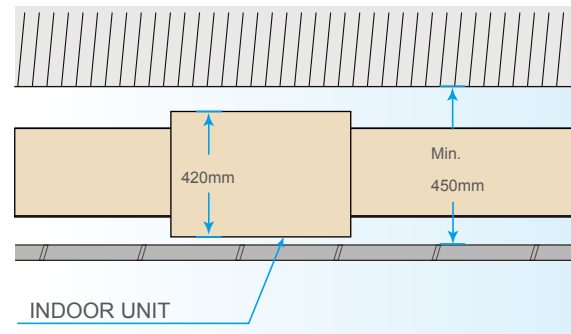
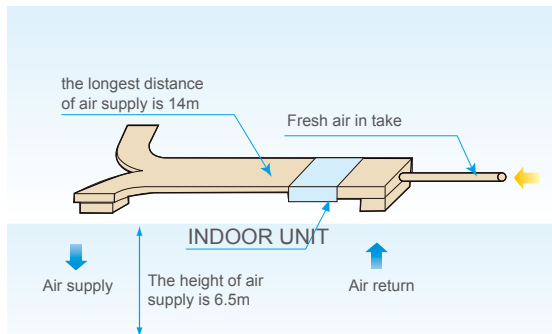

The max distance of air supply is about 45.9ft.(14m) while the height of air supply is about 21.3ft.(6.5m).
 With 16-17/32in(420mm) thickness body, the minimum distance above the ceiling is 17-23/32in(450mm).

Added flexibility with four speed fan

Four speed fan motor(model 71 to 160)

Convenient installation

The EXV is fixed inside the indoor unit (for 71~450 model), no need extra connection.
 Standard filter placed in an aluminum frame, which is removable downward from bottom.
 Flange for air in/outlet duct connection is standard.

Flexible control and convenient for maintenance

Standard wireless remote controller WL-12-CM, and wired remote controller WR-29B-CM is as an option.
 The display board is connected with the E-box in factory, easier trouble-shooting by LED display.
 Easy access filters both in rear & bottom
 Standard functional port such as remote on/off dry contact.

Option

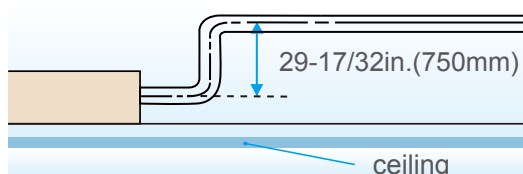

Optional drain pumps with 29-17/32in.(750mm) pumphead.

Double-skin drainage pan

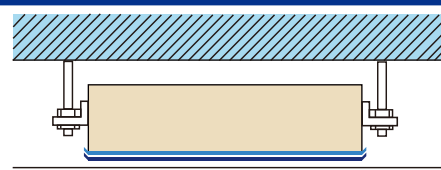

Double-skin drainage pan, double production for your ceiling.(for 71~450 model)

Specifications 60Hz

Model		42VD024H113011010	42VD028H113011010	42VD030H113011010	42VD038H113011010	42VD048H113011010	42VD054H113011010	
Power supply		V-ph-Hz 208-230V~, 1Ph, 60Hz						
Cooling	Capacity	kW	7.1	8	9	11.2	14	16
		BTU	24200	27300	30700	38200	47800	51200
	Input	W	414	402	409	409	527	532
	Rated current	A	1.9	1.9	2.01	2.03	2.31	2.2
Heating	Capacity	kW	8	9	10	12.5	16	16.5
		BTU	27300	30700	34100	42700	54600	56400
	Input	W	414	402	409	409	527	532
	Rated current	A	1.9	1.9	2.01	2.01	2.31	2.2
Indoor air flow (/Hi/Mi/Lo)		m³/h	1720/1532/1338	1690/1560/1320	2252/2030/1610	2198/1978/1570	2969/2694/2469	2969/2694/2469
		CFM	1012/902/788	994/918/777	1326/1195/948	1294/1164/924	1746/1586/1453	1746/1586/1453
Static pressure (Min.~Max.)		Pa	25(25~ 196)	37(37~ 196)	37(37~ 196)	50(50~ 196)	50(50~ 196)	50(50~ 196)
Sound level (sound pressure)		dB(A)	48/46/44.5	48/46/44.5	52/49/47	52/49/47	53/50/48	54/52/50
Indoor unit	Dimension (W×H×D)	mm	952×420×690			952×420×690	1300×420×691	
	Packing (W×H×D)	mm	1090×440×768			1090×440×768	1436×450×768	
	Net/Gross weight	kg	46.5/52	46.5/52	50/56.5	50/56.5	68/70	69.5/76
Refrigerant Type		R410A						
Throttle	Type	EXV						
Design pressure		MPa	4.4/2.6					
Refrigerant piping	Liquid side	mm	Φ9.53			Φ9.53		
	Gas side	mm	Φ15.9			Φ15.9		
Drainage water pipe diameter		mm	OD Φ32					
Controller		Wireless remote controller						

Model		42VD070H113011010	42VD085H113011010	42VD096H113011010	42VD135H113011010	42VD150H113011010		
Power supply		V-ph-Hz 208-230V~, 1Ph, 60Hz						
Cooling	Capacity	kW	20	25	28	40	45	
		BTU	68200	85300	95500	136500	153500	
	Input	W	1800	1800	1800	1600	1600	
	Rated current	A	6.6	6.6	6.6	7.5	7.5	
Heating	Capacity	kW	22.5	26	31.5	45	50	
		BTU	76800	88700	107500	153580	170650	
	Input	W	1800	1800	1800	1600	1600	
	Rated current	A	6.6	6.6	6.6	7.5	7.5	
Indoor air flow (/Hi/Mi/Lo)		m³/h	4700/4100/3599	4700/4100/3599	4700/4100/3599	7180/6150/4600	7180/6150/4600	
		CFM	2766/2413/2118	2766/2413/2118	2766/2413/2118	4226/3620/2708	4226/3620/2708	
Static pressure (Min.~Max.)		Pa	140(50~250)	140(50~250)	160(50~250)	200(50~280)	200(50~280)	
Sound level (sound pressure)		dB(A)	59/55/52	59/55/52	59/55/52	61/59/56	61/59/56	
Indoor unit	Dimension (W×H×D)	mm	1425×500×928			1970×668×902.5		
	Packing (W×H×D)	mm	1509×550×990			2095×800×964		
	Net/Gross weight	kg	115/129	115/129	115/129	235/250		
Refrigerant Type		R410A						
Throttle	Type	EXV						
Design pressure		MPa	4.4/2.6					
Refrigerant piping	Liquid side	mm	Φ9.53×2			Φ12.7×2		
	Gas side	mm	Φ15.9×2			Φ22.2×2		
Drainage water pipe diameter		mm	OD Φ32					
Controller		Wireless remote controller						

Notes:

1. Nominal cooling capacities are based on the following conditions: return air temperature: 80.6°F(27°C)DB,66.2°F(19°C)WB, and outdoor temperature: 95°F(35°C)DB, equivalent ref. Piping: 26.25ft(8m) (horizontal).

2. Nominal heating capacities are based on the following conditions: return air temperature: 68°F(20°C)DB, outdoor temperature: 44.6°F(7°C)DB, 42.8°F(6°C)WB, and equivalent ref. Piping: 26.25ft(8m) (horizontal).

3. Sound Level is measured 4.59ft. (1.4m) below the unit.

* Specifications are subject to change without prior notice for product improvement.

Specifications 50Hz

Model		42VD028H112011010	42VD032H112011010	42VD036H112011010	42VD036H112011010	42VD048H112011010	42VD054H112011010	
Power supply		V-Ph-Hz 220-240V, 1Ph, 50Hz						
Cooling	Capacity	kW	7.1	8	9	11.2	14	16
		BTU	24200	27300	30700	38200	47800	51200
	Input	W	240	240	398	518	648	873
	Rated current	A	1.1	1.1	1.8	2.3	2.7	3.6
Heating	Capacity	kW	8	9	10	12.5	16	17
		BTU	27300	30700	34100	42700	54600	56400
	Input	W	240	240	398	518	648	873
	Rated current	A	1.1	1.1	1.8	2.3	2.7	3.6
Indoor air flow (Hi/Mi/Lo)		m ³ /h	1443/1361/1218	1416/1338/1220	1915/1741/1518	2116/1936/1520	3000/2618/2226	3620/2044/2744
		CFM	849/801/717	883/788/718	1148/1025/893	1426/1140/895	1766/1541/1310	2131/1792/1615
Indoor external static pressure		Pa	40(30~196)	40(30~196)	40(30~196)	50(30~196)	50(30~196)	50(30~196)
Indoor noise level (Sound pressure)(Hi/Mi/Lo)		dB(A)	48/46/44	48/46/44.5	52/49/47	52/49/47	53/50/48	54/52/50
Indoor unit	Dimension (W×H×D)	mm	952×420×690				1200×400×600	
	Packing (W×H×D)	mm	1090×440×768				1436×450×768	
	Net/Gross weight	Kg	45/50	45/50	46.5/52.4	50.6/56	68/70	70/77.5
Refrigerant type		R410A						
Throttle type		Type	EXV					
Design pressure		MPa	4.4/2.6					
Refrigerant piping	Liquid side	mm	Φ9.53			Φ9.53		
	Gas side	mm	Φ15.9			Φ15.9		
Drainage pipe diameter		mm	ODΦ32					
Controller		Wireless Controller						

Model		42VD070H112011010	42VD085H112011010	42VD096H112011010	42VD135H112011010	42VD150H112011010	42VD190H112011010	
Power supply		V-Ph-Hz 220-240V, 1Ph, 50Hz						
Cooling	Capacity	kW	20	25	28	40	45	56
		BTU	68200	85300	95500	136500	153500	170600
	Input	W	1800	1800	1800	2700	2700	3400
	Rated current	A	6.6	6.6	6.6	12.5	12.5	15.5
Heating	Capacity	kW	22.5	26	31.5	45	50	63
		BTU	76800	88700	107500	153500	170600	215000
	Input	W	1800	1800	1800	2700	2700	3400
	Rated current	A	6.6	6.6	6.6	12.5	12.5	15.5
Indoor air flow (Hi/Mi/Lo)		m ³ /h	4700/4100/3599	4700/4100/3599	4700/4100/3599	7472/6072/4995	7472/6072/4995	9550/7950/6600
		CFM	2766/2413/2118	2766/2413/2118	2766/2413/2118	4395/3572/2938	4395/3572/2938	5618/4676/3882
Indoor external static pressure		Pa	140(50~250)	140(50~250)	160(50~250)	200(50~280)	200(50~280)	200(50~280)
Indoor noise level (Sound pressure)(Hi/Mi/Lo)		dB(A)	59/55/52	59/55/52	59/55/52	61/59/56	61/59/56	63/60/57
Indoor unit	Dimension (W×H×D)	mm	1425×500×928			1970×668×902.5		
	Packing (W×H×D)	mm	1509×550×990			2095×800×964		
	Net/Gross weight	Kg	115/129	115/129	115/129	232/245	232/245	235/250
Refrigerant type		R410A						
Throttle type		Type	EXV					
Design pressure		MPa	4.4/2.6					
Refrigerant piping	Liquid side	mm	Φ9.53×2			Φ12.7×2	Φ12.7×2	Φ15.9×2
	Gas side	mm	Φ15.9×2			Φ28.6×2	Φ28.6×2	Φ28.6×2
Drainage pipe diameter		mm	ODΦ32					
Controller		Wireless Controller						

Notes:

- Nominal cooling capacities are based on the following conditions: return air temperature: 80.6°F(27°C)DB,66.2°F(19°C) WB, and outdoor temperature: 95°F(35°C)DB, equivalent ref. Piping:26.25ft(8m) (horizontal).
- Nominal heating capacities are based on the following conditions: return air temperature: 68°F(20°C)DB, outdoor temperature: 44.6°F(7°C)DB,42.8°F(6°C)WB, and equivalent ref. Piping: 26.25ft(8m) (horizontal).
- Sound Level is measured 4.59ft. (1.4m) below the unit.

* Specifications are subject to change without prior notice for product improvement.

Ceiling & Floor



-  Auto Restart
-  Cleanable Panel
-  Auto Addressing
-  Anti-Cold Air Function
-  Follow Me
-  LED Display

Panel with LED display

The front panel and display panel have different colors to choose: white and brown to big panel, blue and brown for small panel, and the other colors can be customized according to the customers' demands.

Convenient for installation

- The ceiling type can be easily installed into a corner of the ceiling even if the ceiling is very narrow
- It is especially useful when installation of an air conditioner in the center of the ceiling is impossible due to a structure such as one lighting

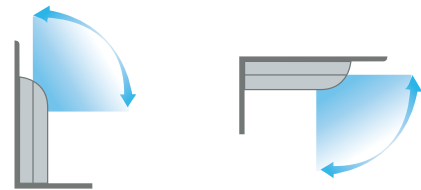

The unit can be installed either horizontally on the ceiling or vertically against the wall.

Low noise, creates quiet and comfortable environment

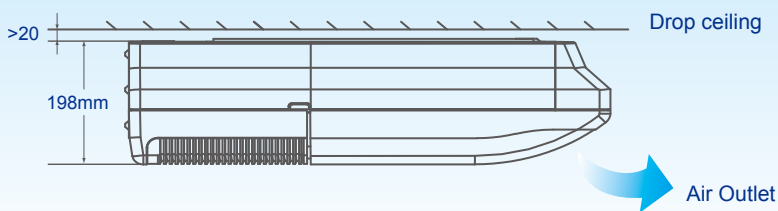

- Slim and sleek design starting at just 66lbs.(30kg) in weight means quick,easy & neat installation.
- Low noise operation, lowest to 36dB(A)

Auto swing and wide angle air flow

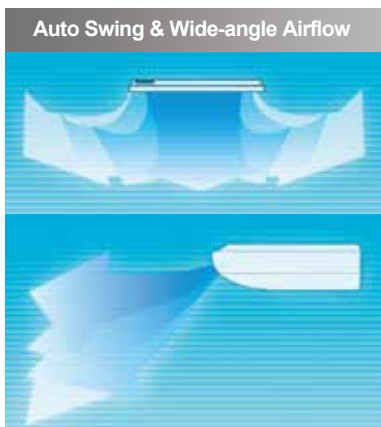

- 1.The unit has auto horizontal swing and auto vertical swing function, which supplies more even and comfortable airflow.
- 2.Three airflow speed: high/middle/low, double air guides.
- 3.Adoption of the electronic expansion valve, ensure precise flow control, as well lower modulation noise when EXV operating.
- 4.Smooth airflow with less turbulence. Due to the multiple-blade fan and the air guide design, the airflow is getting smoother and more comfortable.

Specifications 60Hz

Model		42VF012H113000010	42VF016H113000010	42VF020H113000010	42VF024H113000010	42VF028H113000010	
Power supply		V- Ph-Hz	208-230V-1Ph-60Hz				
Cooling	Capacity	kW	3.6	4.5	5.6	7.1	8
		Btu/h	12300	15400	19100	24200	27300
	Input	W	50	148	148	148	183
	Rated current	A	0.55	0.55	0.55	0.57	0.6
Heating	Capacity	kW	4	5	6.3	8	9
		Btu/h	13600	17100	21500	27300	30700
	Input	W	50	148	148	148	183
	Rated current	A	0.55	0.55	0.55	0.57	0.6
Indoor air flow (H/M/L)		m ³ /h	600/480/400	750/650/550	750/650/550	750/650/550	1200/900/700
		CFM	353/282.5/235.4	441.1/382.6/323.7	441.1/382.6/323.7	441.1/382.6/323.7	706/529.7/412
Indoor noise level (H/M/L)		dB(A)	40/38/36	43/41/38	43/41/38	43/41/38	45/43/40
Indoor unit	Dimension (W×H×D)	mm	990×203×660	990×203×660	990×203×660	990×203×660	1280×203×660
	Packing (W×H×D)	mm	1089×296×744	1089×296×744	1089×296×744	1089×296×744	1379×296×744
	Net/Gross weight	kg	26/32	28/34	28/34	28/34	34.5/41
Refrigerant type			R410A	R410A	R410A	R410A	R410A
Throttle		Type	EXV	EXV	EXV	EXV	EXV
Design pressure(H/L)		MPa	4.4/2.6	4.4/2.6	4.4/2.6	4.4/2.6	4.4/2.6
Refrigerant piping	Liquid side		Φ6.35	Φ6.35	Φ9.52	Φ9.52	Φ9.52
	Gas side	in.(mm)	Φ12.7		Φ15.9	Φ15.9	Φ15.9
Drainage water pipe diameter		in.(mm)	OD Φ25	OD Φ25	OD Φ25	OD Φ25	OD Φ25
Controller			Wireless remote controller				

Notes:

- Nominal cooling capacities are based on the following conditions: return air temperature: 80.6°F(27°C)DB,66.2°F(19°C)WB, and outdoor temperature: 95°F(35°C)DB,equivalent ref. piping: 26.25ft. (8m) (horizontal).
 - Nominal heating capacities are based on the following conditions: return air temperature: 68°F(20°C)DB, outdoor temperature: 44.6°F(7°C)DB,42.8°F(6°C)WB, and equivalent ref. Piping: 26.25ft.(8m) (horizontal).
 - Floor standing :Sound level is measured 3.28ft(1m) from air-outlet in horizontal distance, 3.28ft(1m) above the floor in vertical distance. Ceiling mounted:Sound level is measured 3.28ft(1m) from air-outlet in horizontal distance,3.28ft(1m) from air-outlet in vertical distance.
- * Specifications are subject to change without prior notice for product improvement.

Specifications 60Hz

Model			42VF030H113000010	42VF036H113000010	42VF048H113000010	42VF054H113000010
Power supply		V- Ph-Hz	208-230V-1Ph~60Hz			
Cooling	Capacity	kW	9	11.2	14	16
		Btu/h	30700	38200	47800	54600
	Input	W	183	245	245	378
	Rated current	A	0.6	0.83	0.83	1.75
Heating	Capacity	kW	10	12.5	15	18
		Btu/h	34100	42700	52900	61400
	Input	W	183	245	245	378
	Rated current	A	0.6	0.83	0.83	1.75
Indoor air flow (H/M/L)		m ³ /h	1200/900/700	1980/1860/1730	1980/1860/1730	2300/2100/1800
		CFM	706/529.7/412	1165/1095/1018	1165/1095/1018	1354/1236/1060
Indoor noise level (H/M/L)		dB(A)	45/43/40	47/45/42	47/45/42	52
Indoor unit	Dimension (W×H×D)	mm	1280×203×660	1670×244×680	1670×244×680	1670x285x680
	Packing (W×H×D)	mm	1379x296x744	1764x329x760	1764x329x760	1775x377x760
	Net/Gross weight	kg	34.5/41	54/59	54/59	57.5/63.5
Refrigerant type			R410A	R410A	R410A	R410A
Throttle		Type	EXV	EXV	EXV	EXV
Design pressure(H/L)		MPa	4.4/2.6	4.4/2.6	4.4/2.6	4.4/2.6
Refrigerant piping	Liquid side		Φ9.52	Φ9.52	Φ9.52	Φ9.52
	Gas side	in.(mm)	Φ15.9	Φ15.9	Φ15.9	Φ15.9
Drainage water pipe diameter		in.(mm)	OD Φ25	OD Φ25	OD Φ25	OD Φ25
Controller			Wireless remote controller			

Notes:

- Nominal cooling capacities are based on the following conditions: return air temperature: 80.6°F(27°C)DB,66.2°F(19°C)WB, and outdoor temperature: 95°F(35°C)DB, equivalent ref. piping: 26.25ft. (8m) (horizontal).
 - Nominal heating capacities are based on the following conditions: return air temperature: 68°F(20°C)DB, outdoor temperature: 44.6°F(7°C)DB,42.8°F(6°C)WB, and equivalent ref. Piping: 26.25ft.(8m) (horizontal).
 - Floor standing :Sound level is measured 3.28ft(1m) from air-outlet in horizontal distance, 3.28ft(1m) above the floor in vertical distance. Ceiling mounted:Sound level is measured 3.28ft(1m) from air-outlet in horizontal distance,3.28ft(1m) from air-outlet in vertical distance.
- * Specifications are subject to change without prior notice for product improvement.

Specifications 50Hz

Sale Model			42VF012H112000010	42VF016H112000010	42VF020H112000010	42VF024H112000010	42VF028H112000010
Power supply		V-ph-Hz	220~240-1-50	220~240-1-50	220~240-1-50	220~240-1-50	220~240-1-50
Cooling	Capacity	kW	3.6	4.5	5.6	7.1	8
		BTU	12300	15400	19100	24200	27300
	Input	W	34	125	125	125	143
	Rated current	A	0.55	0.55	0.55	0.57	0.6
Heating	Capacity	kW	4	5	6	8	9
		BTU	13600	17100	21500	27300	30700
	Input	W	34	125	125	125	143
	Rated current	A	0.55	0.55	0.55	0.57	0.6
Indoor air flow (Hi/Mi/Lo)		m³/h	650/570/500	800/600/500	800/600/500	800/600/500	1200/900/700
		CFM	383/335/294	471/353/294	471/353/294	471/353/294	706/530/412
Sound level (sound pressure)		dB(A)	40/38/36	43/41/38	43/41/38	43/41/38	45/43/40
Indoor unit	Dimension (W×H×D)	mm	990×660×206	990×660×206	990×660×206	990×660×206	1280×660×206
	Packing (W×H×D)	mm	1090×745×297	1090×745×297	1090×745×297	1090×745×297	1380×745×297
	Net/Gross weight	kg	26/32	28/34	28/34	28/34	34.5/41
Refrigerant	Type		R410A	R410A	R410A	R410A	R410A
Design pressure		MPa	4.2/2.5	4.2/2.5	4.2/2.5	4.2/2.5	4.2/2.5
Refrigerant piping	Liquid side	mm	Φ6.35	Φ6.35	Φ9.53	Φ9.53	Φ9.53
	Gas side	mm	Φ12.7	Φ12.7	Φ15.9	Φ15.9	Φ15.9
Drainage water pipe diameter		mm	ODΦ16	ODΦ16	ODΦ16	ODΦ16	ODΦ16
Controller			Wireless controller				







Sale Model			42VF030H112000010	42VF036H112000010	42VF048H112000010	42VF054H112000010
Power supply		V-ph-Hz	220~240-1-50	220~240-1-50	220~240-1-50	220~240-1-50
Cooling	Capacity	kW	9	11.2	14	16
		BTU	30700	38200	47800	54600
	Input	W	143	182	182	300
	Rated current	A	0.6	0.83	0.83	1.41
Heating	Capacity	kW	10	12.5	15.5	15.5
		BTU	34100	42700	52900	52900
	Input	W	143	182	182	300
	Rated current	A	0.6	0.83	0.83	1.41
Indoor air flow (Hi/Mi/Lo)		m³/h	1200/900/700	1980/1860/1730	1980/1860/1730	1980/1860/1730
		CFM	706/530/412	1165/1095/1018	1165/1095/1018	1165/1095/1018
Sound level (sound pressure)		dB(A)	45/43/40	47/45/42	47/45/42	47/45/42
Indoor unit	Dimension (W×H×D)	mm	1280×660×206	1670×680×244	1670×680×244	1670×680×244
	Packing (W×H×D)	mm	1380×745×297	1765×760×330	1765×760×330	1765×760×330
	Net/Gross weight	kg	34.5/41	54/59	54/59	57.5/63.5
Refrigerant	Type		R410A	R410A	R410A	R410A
Design pressure		MPa	4.2/2.5	4.2/2.5	4.2/2.5	4.2/2.5
Refrigerant piping	Liquid side	mm	Φ9.53	Φ9.53	Φ9.53	Φ9.53
	Gas side	mm	Φ15.9	Φ15.9	Φ15.9	Φ15.9
Drainage water pipe diameter		mm	ODΦ16	ODΦ16	ODΦ16	ODΦ16
Controller			Wireless controller			

Notes:

- Nominal cooling capacities are based on the following conditions: return air temperature: 80.6°F(27°C)DB,66.2°F(19°C)WB, and outdoor temperature: 95°F(35°C)DB,equivalent ref. piping: 26.25ft. (8m) (horizontal) .
 - Nominal heating capacities are based on the following conditions: return air temperature: 68°F(20°C)DB, outdoor temperature: 44.6°F(7°C)DB,42.8°F(6°C)WB, and equivalent ref. Piping: 26.25ft.(8m) (horizontal).
 - Floor standing :Sound level is measured 3.28ft(1m) from air-outlet in horizontal distance, 3.28ft(1m) above the floor in vertical distance. Ceiling mounted:Sound level is measured 3.28ft(1m) from air-outlet in horizontal distance,3.28ft(1m) from air-outlet in vertical distance.
- * Specifications are subject to change without prior notice for product improvement.

Wall-mounted



-  Auto Restart
-  Auto Addressing
-  Cleanable Panel
-  Anti-Cold Air Function
-  Follow Me
-  LED Display

Panel with LED display

The front panel and display panel have different colors to choose: white and brown for big panel, blue and brown for small panel.

Convenient installation

- Multi-refrigerant outlet pipe method: left\right\rear, more flexible for installation.
- The EXV is built-in the indoor unit, compact size, longer the connection pipe; Gas pipe: 18-27/64in.(468mm)/Liquid pipe: 21-21/32in.(550mm), more flexible for the installation.
- Adopts new type fixing plate, which means easy to install and stable.

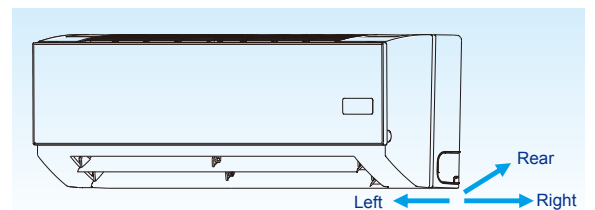

Auto swing louver

auto swing louver function ensures that the air direction corresponds to the mode selected.

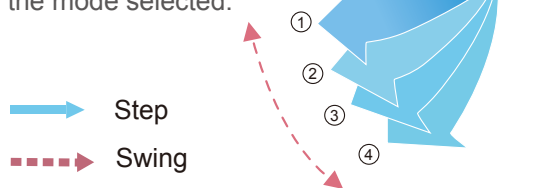

Easy maintenance

The front panel can be removed for easy maintenance access.



Optimal comfort through better flow control and quiet operations

The mechanical expansion valve offers 2,000-stage element positions to ensure precise flow control and less modulation noise when the EXV is operating for a quiet and comfortable environment. Three air flow speeds: low, medium and high; double air guides. Smoother airflow and less turbulence is ensured by the multi-blade fan and the air guide design.



Specifications 60Hz

Model			42VH007H113000101	42VH009H113000101	42VH012H113000101	42VH016H113000101
Power supply		V- Ph-Hz	208-230V-1Ph-60Hz			
Cooling	Capacity	kW	2.2	2.8	3.6	4.5
		Btu/h	7500	9600	12300	15400
	Input	W	25	28	30	51
	Rated current	A	0.14	0.14	0.14	0.2
Heating	Capacity	kW	2.4	3.2	4	5
		Btu/h	8200	10900	13600	17100
	Input	W	25	28	30	51
	Rated current	A	0.14	0.14	0.14	0.2
Indoor air flow (H/M/L)		m³/h	525/480/430	525/480/430	590/520/480	860/755/630
		CFM	309/282.5/253	309/282.5/253	347/306/282.5	506/444/370.8
Indoor noise level (H/M/L)		dB(A)	35/32/29	35/32/29	35/32/29	40/38/34
Indoor unit	Dimension (W×H×D)	mm	915×230×290	915×230×290	915×230×290	1072×230×315
	Packing (W×H×D)	mm	1020×315×390	1020×315×390	1020×315×390	1180×315×415
	Net/Gross weight	kg	13/16.8	13/16.8	13/16.8	15.1/19.5
Panel		Type	S Type	S Type	S Type	S Type
Refrigerant type			R410A			
Throttle		Type	EXV			
Design pressure		MPa	4.4/2.6			
Refrigerant piping	Liquid side	mm	Φ6.35	Φ6.35	Φ6.35	Φ6.35
	Gas side	mm	Φ12.7	Φ12.7	Φ12.7	Φ12.7
Drainage water pipe diameter		mm	OD 16.5			
Controller			Wireless remote controller			

Model			42VH020H113000101	42VH024H113000100	42VH028H113000100	42VH030H113000100
Power supply		V- Ph-Hz	208-230V-1Ph-60Hz			
Cooling	Capacity	kW	5.6	7.1	8	9
		Btu/h	19100	24200	27300	30700
	Input	W	51	79	95	95
	Rated current	A	0.2	0.33	0.39	0.39
Heating	Capacity	kW	6.3	8	9	10
		Btu/h	21500	27300	30700	34100
	Input	W	51	79	95	95
	Rated current	A	0.2	0.33	0.39	0.39
Indoor air flow (H/M/L)		m³/h	925/860/755	1190/780/580	1320/840/640	1320/840/640
		CFM	544/506/444	700/459/341	776/494/376	776/494/376
Indoor noise level (H/M/L)		dB(A)	40/38/34	45/42/41	48/43/38	49/43/38
Indoor unit	Dimension (W×H×D)	mm	1072×230×315	1250×245×325	1250×245×325	1250×245×325
	Packing (W×H×D)	mm	1180×315×415	1345×335×430	1345×335×430	1345×335×430
	Net/Gross weight	kg	15.1/19.5	19.9/25	19.9/25	19.9/25
Panel		Type	S Type	R Type	R Type	R Type
Refrigerant type			R410A			
Throttle		Type	EXV			
Design pressure		MPa	4.4/2.6			
Refrigerant piping	Liquid side	mm	Φ9.53	Φ9.53	Φ9.53	Φ9.53
	Gas side	mm	Φ15.9	Φ15.9	Φ15.9	Φ15.9
Drainage water pipe diameter		mm	OD 16.5			
Controller			Wireless remote controller			

Notes:

- Nominal cooling capacities are based on the following conditions: return air temperature : 80.6°F(27°C)DB,66.2°F(19°C)WB,and outdoor temperature: 95°F(35°C)DB,equivalent ref. piping: 26.25ft(8m)(horizontal)
 - Nominal heating capacities are based on the following conditions: return air temperature: 68°F(20°C)DB, outdoor temperature: 44.6°F(7°C)DB,42.8°F(6°C)WB, and equivalent ref. Piping: 26.25ft(8m)(horizontal)
 - Sound level is measured 3.28ft.(1m) below the air out-let both in horizontal and vertical distance.
- * Specifications are subject to change without prior notice for product improvement.

Specifications 50Hz

Model		42VH007H112000101	42VH009H112000101	42VH012H112000101	42VH016H112000101	
Power supply		V- Ph-Hz	220-240V, 1Ph, 50Hz			
Cooling	Capacity	kW	2.2	2.8	3.6	4.5
		BTU	7500	9600	12300	15400
	Input	W	31	31	31	44
	Rated current	A	0.14	0.14	0.14	0.2
Heating	Capacity	kW	2.4	3.1	4	5
		BTU	8200	10900	13600	17100
	Input	W	31	31	31	44
	Rated current	A	0.14	0.14	0.14	0.2
Indoor air flow (H/M/L)		m ³ /h	525/480/430	525/480/430	590/520/480	860/755/630
		CFM	309/282/253	309/282/253	347/306/283	506/444/371
Indoor noise level (sound pressure)		dB(A)	35/32/29	35/32/29	35/32/29	40/38/34
Indoor unit	Dimension (W×H×D)	mm	915×290×230	915×290×230	915×290×230	1072×315×230
	Packing (W×H×D)	mm	1020×390×315	1020×390×315	1020×390×315	1180×415×315
	Net/Gross weight	kg	13/16.5	13/16.5	13/16.5	15.1/18.8
Panel		Type	S Type	S Type	S Type	S Type
Refrigerant type			R410A			
Throttle		Type	EXV			
Design pressure		MPa	4.4/2.6			
Refrigerant piping	Liquid side	mm	Φ6.35	Φ6.35	Φ6.35	Φ6.35
	Gas side	mm	Φ12.7	Φ12.7	Φ12.7	Φ12.7
Drainage water pipe dia.		mm	ODΦ16.5			
Controller			Wireless controller			

Model		42VH020H112000101	42VH024H112000102	42VH028H112000102	42VH030H112000102	
Power supply		V- Ph-Hz	220-240V, 1Ph, 50Hz			
Cooling	Capacity	kW	5.6	7.1	8	9
		BTU	19100	24200	27300	30700
	Input	W	44	75	86	86
	Rated current	A	0.2	0.33	0.39	0.39
Heating	Capacity	kW	6	8	9	10
		BTU	21500	27300	30700	34100
	Input	W	44	75	86	86
	Rated current	A	0.2	0.33	0.39	0.39
Indoor air flow (H/M/L)		m ³ /h	925/860/755	1190/780/580	1320/840/640	1320/840/640
		CFM	544/506/444	700/459/341	776/494/376	776/494/376
Indoor noise level (sound pressure)		dB(A)	40/38/34	47/43/42	48/43/38	49/43/38
Indoor unit	Dimension (W×H×D)	mm	1072×315×230	1250×245×325	1250×245×325	1250×245×325
	Packing (W×H×D)	mm	1180×415×315	1345×335×430	1345×335×430	1345×335×430
	Net/Gross weight	kg	15.1/18.8	19.9/25	19.9/25	19.9/25
Panel		Type	S Type	R Type	R Type	R Type
Refrigerant type			R410A			
Throttle		Type	EXV			
Design pressure		MPa	4.4/2.6			
Refrigerant piping	Liquid side	mm	Φ9.53	Φ9.53	Φ9.53	Φ9.53
	Gas side	mm	Φ15.9	Φ15.9	Φ15.9	Φ15.9
Drainage water pipe dia.		mm	ODΦ16.5			
Controller			Wireless controller			

Notes:

- Nominal cooling capacities are based on the following conditions: return air temperature : 80.6°F(27°C)DB,66.2°F(19°C)WB,and outdoor temperature: 95°F(35°C)DB,equivalent ref. piping: 26.25ft(8m)(horizontal)
 - Nominal heating capacities are based on the following conditions: return air temperature: 68°F(20°C)DB, outdoor temperature: 44.6°F(7°C)DB,42.8°F(6°C)WB, and equivalent ref. Piping: 26.25ft(8m)(horizontal)
 - Sound level is measured 3.28ft.(1m) below the air out-let both in horizontal and vertical distance.
- * Specifications are subject to change without prior notice for product improvement.

Fresh Air Processing Unit

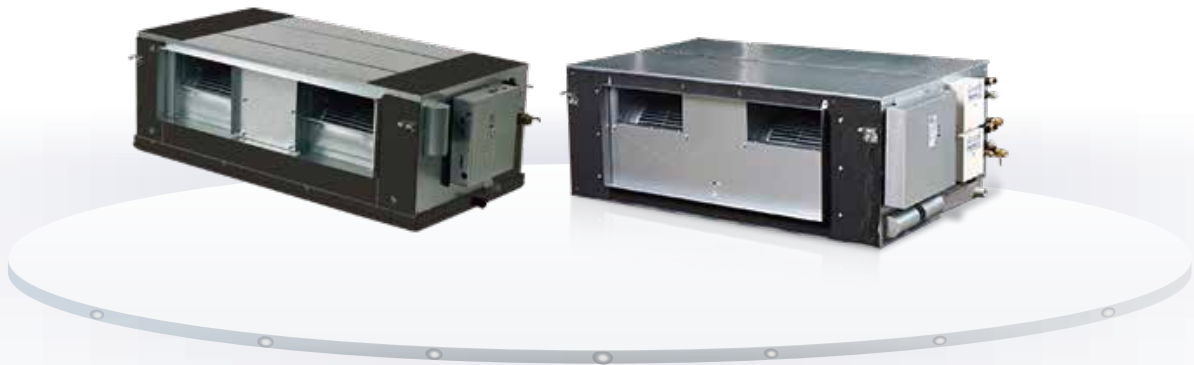

Healthy and comfortable

Fresh air is imported, provides a healthy and comfortable living environment.

100% Fresh air processing unit

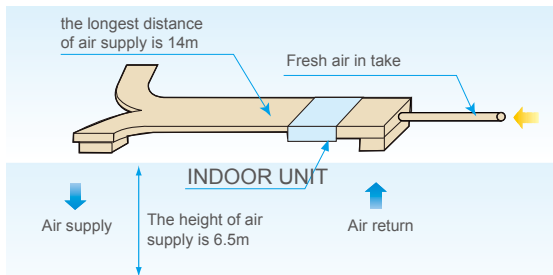

Both fresh air filtration and heating/cooling can be achieved in a single system. Indoor units and fresh air processing unit can be connected to the same refrigerant system, increasing design flexibility and greatly reducing total system costs.

High external static pressure

External static pressure can be up to 196Pa(125~140 models) and 280Pa(200~280 models) for more flexible duct applications. The maximal distance of air supply is about 45.9ft.(14m) and the maximum height of air supply is about 21.3ft.(6.5m).

Innovative air supply technology for excellent room temperature control

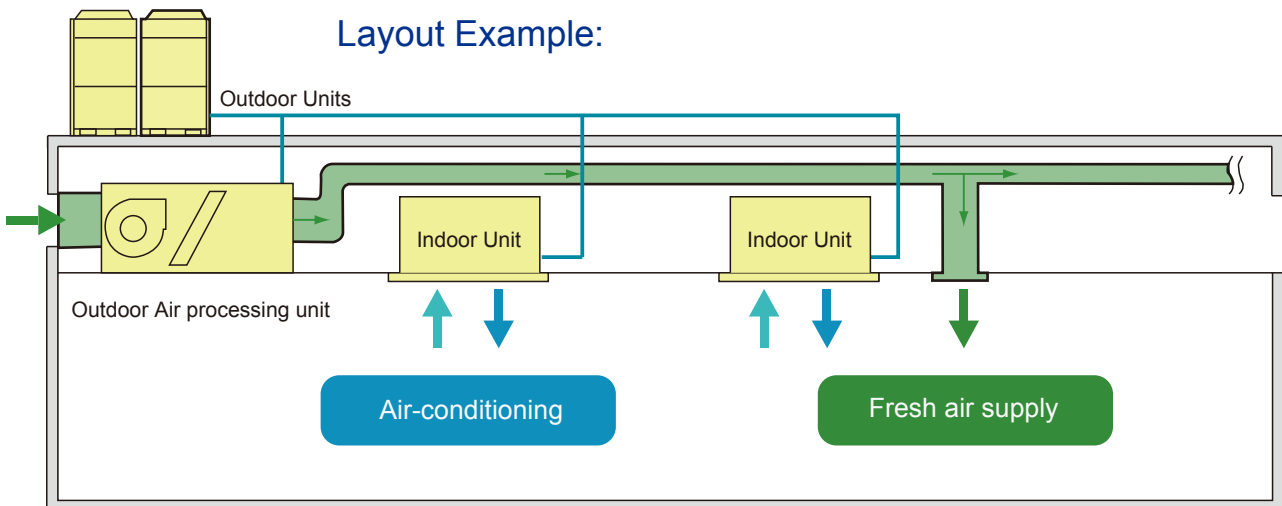

Specifications 60Hz

Sale Model		42VD042H113211010	42VD048H113211010	42VD070H113211010	42VD085H113211010	42VD096H113211010	
Power supply		V-Ph-Hz	208-230V-1Ph~60Hz				
Cooling	Capacity	kW	12.5	14	20	25	28
		Btu	42600	47800	68200	85300	95500
	Power Input	W	468	468	616	616	616
	Rated Current	A	2.4	2.4	4.2	4.2	4.2
Heating	Capacity	kW	10.5	12	18	20	22
		BTU	36000	41000	61400	68200	75000
	Power Input	W	468	468	616	616	616
	Rated Current	A	2.4	2.4	4.2	4.2	4.2
Indoor air flow (H/M/L)		m³/h	2142/1870/1611	2142/1870/1611	3210/2700/2200	3205/2750/2300	3205/2750/2300
		CFM	1261/1101/948	1261/1101/948	1889/1589/1295	1886/1619/1354	1886/1619/1354
Indoor external static pressure (H)		Pa	50(50~196)	50(50~196)	200(50~280)	200(50~280)	200(50~280)
Indoor noise level (Sound pressure)(H/M/L)		dB(A)	54/52/50	54/52/50	54/53/51	55/54/52	55/54/52
Indoor unit	Dimension (W×H×D)	mm	1300×420×690			1443×470×810	
	Packing (W×H×D)	mm	1436×450×768			1509×550×990	
	Net/Gross weight	Kg	69.5/76	69.5/76	114/124	114/124	114/124
Refrigerant type			R410A	R410A	R410A	R410A	R410A
Throttle type			EXV			EXV	
Design pressure(H/L)		MPa	4.4/2.6	4.4/2.6	4.2/2.0	4.2/2.0	4.2/2.0
Liquid side		mm	Φ9.53	Φ9.53	Φ9.53	Φ9.53	Φ9.53
Refrigerant piping	Gas side	mm	Φ15.9	Φ15.9	Φ15.9	Φ15.9	Φ15.9
Drainage pipe diameter		mm	OD Φ32	OD Φ32	OD Φ32	OD Φ32	OD Φ32
Controller			Wireless remote controller				

Notes:

- Nominal cooling capacities are based on the following conditions: outdoor air temperature:91.4°F(33°C)DB, 75.2°F(24°C)WB, equivalent ref. piping:26.25ft. (8m)(horizontal).
- Nominal heating capacities are based on the following conditions: outdoor air temperature:32°F(0°C)DB, 30.2°F(-1°C)WB, equivalent ref. piping:26.25ft. (8m)(horizontal).
- Sound level is measured 4.59ft.(1.4m) from the air out-let.

* External static pressure are based on high speed indoor airflow.

* Specifications are subject to change without prior notice for product improvement.

Connection Conditions:

The following restrictions must be observed in order to maintain the indoor units connected to the same system.

* When outdoor-air processing units are connected, the total connection capacity must be within 50% to 100% of that of the outdoor units.

* When outdoor-air processing units and standard indoor units are connected, the total connection capacity of the outdoor-air processing units must not exceed 30% of that of the outdoor units.

* Outdoor-air processing units can be used without indoor units.

Specifications 50Hz

Sale Model		42VD042H112211010	42VD048H112211010	42VD070H112211010	42VD085H112211010	42VD096H112211010	
Power supply		V-Ph-Hz	220-240V-1Ph-50Hz				
Cooling	Capacity	kW	12.5	14	20	25	28
		BTU	42600	47800	68200	85300	95500
	Power input	W	568	568	1300	1350	1350
	Rated current	A	2.55	2.55	5.80	6.00	6.00
Heating	Capacity	kW	10.5	16	18	20	22
		BTU	36000	41000	61400	68200	75000
	Power input	W	568	568	1300	1350	1350
	Rated current	A	2.55	2.55	5.80	6.00	6.00
Max. current		A	2.4	2.4	5.3	5.6	5.6
Indoor air flow (Hi/Mid/Lo)		m³/h	2142/1870/1611	2142/1870/1611	2870/2620/2150	3005/2700/2250	3005/2700/2250
		CFM	1261/1101/948	1261/1101/948	1689/1542/1265	1766/1589/1324	1766/1589/1324
Indoor external static pressure (Hi)		Pa	30~220	30~220	50~260	50~260	50~260
Noise level (Sound pressure)(Hi/Mid/Lo)		dB(A)	54/52/50	54/52/50	54/53/51	55/54/52	55/54/52
Indoor unit	Dimension (W*H*D)	mm	1368*420*691	1368*420*691	1443*470*810	1443*470*810	1443*470*810
	Packing (W*H*D)	mm	1436*450*768	1436*450*768	1509*550*990	1509*550*990	1509*550*990
	Net/Gross weight	Kg	69.5/76	69.5/76	115/125	115/125	115/125
Refrigerant type			R410A	R410A	R410A	R410A	R410A
Throttle type			EXV				
Design pressure		MPa	4.2/2.0	4.2/2.0	4.2/2.0	4.2/2.0	4.2/2.0
Refrigerant piping	Liquid side		Φ9.52	Φ9.52	Φ9.52	Φ9.52	Φ9.52
	Gas side	mm	Φ15.9	Φ15.9	Φ15.9	Φ15.9	Φ15.9
Drainage pipe diameter		mm²	OD Φ25	OD Φ25	OD Φ32	OD Φ32	OD Φ32
Controller			Wireless Controller				
Operation temp (outdoor)		°C	COOLING +20~+43; HEATING -5 ~20				

Notes:

- Nominal cooling capacities are based on the following conditions: outdoor air temperature:91.4°F(33°C)DB, 75.2°F(24°C)WB, equivalent ref. piping:26.25ft. (8m)(horizontal).
- Nominal heating capacities are based on the following conditions: outdoor air temperature:32°F(0°C)DB, 30.2°F(-1°C)WB, equivalent ref. piping:26.25ft. (8m)(horizontal).
- Sound level is measured 4.59ft.(1.4m) from the air out-let.

* External static pressure are based on high speed indoor airflow.
 * Specifications are subject to change without prior notice for product improvement.

Connection Conditions:

The following restrictions must be observed in order to maintain the indoor units connected to the same system.

- * When outdoor-air processing units are connected, the total connection capacity must be within 50% to 100% of that of the outdoor units.
- * When outdoor-air processing units and standard indoor units are connected, the total connection capacity of the outdoor-air processing units must not exceed 30% of that of the outdoor units.
- * Outdoor-air processing units can be used without indoor units.

A low-angle, upward-looking photograph of several modern skyscrapers. The buildings are primarily glass and steel, with one prominent building on the right featuring a distinctive white structural frame. The sky is bright blue with scattered white clouds. A semi-transparent dark grey horizontal band is overlaid across the middle of the image, containing the text 'Control Systems' and a double arrow symbol. The overall composition is dynamic and emphasizes the height and scale of the architecture.

Control Systems >>

Control Systems

Network Control

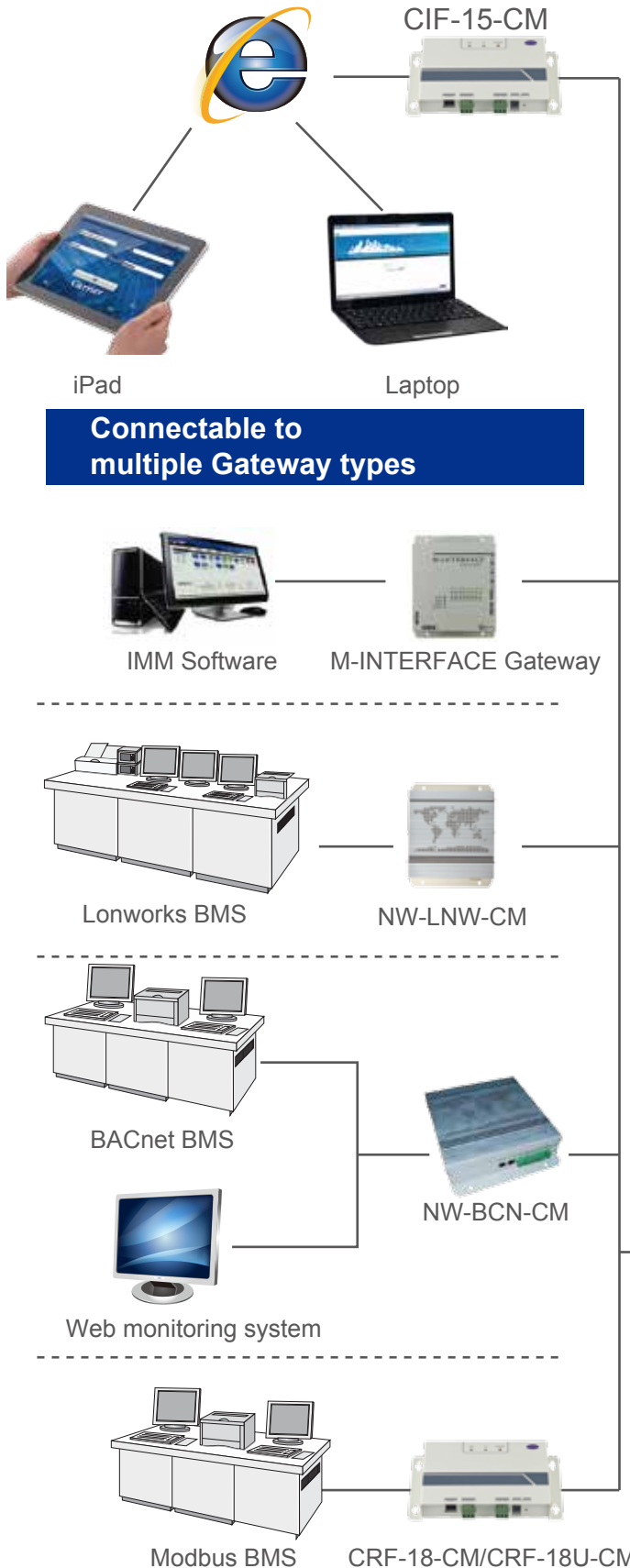

Centralized Control

Indoor Centralized Controller (Touch key)



CRF-30-CM

X,Y,E

Indoor Centralized Controller



CRF-10-CM

X,Y,E

Outdoor Centralized Monitor



CRC-10-CM

F1,F2,E

K1,K2,E

Note: The wires in the diagram show the signal flows only, while not represent the actual connecting ways.

Individual control

Wired controller

- WR-12-CM
- WR-29B-CM
- WR-120B-CM
- WR-90D-CM



Remote controller

- WL-12-CM
- WL-14-CM



Accessories

Card-key Interface CA-NIM05



CA-NIM05



Card-key



Wired controller

Infrared Sensor CA-NIM09



Infrared control box



Infrared sensor module



Wired controller

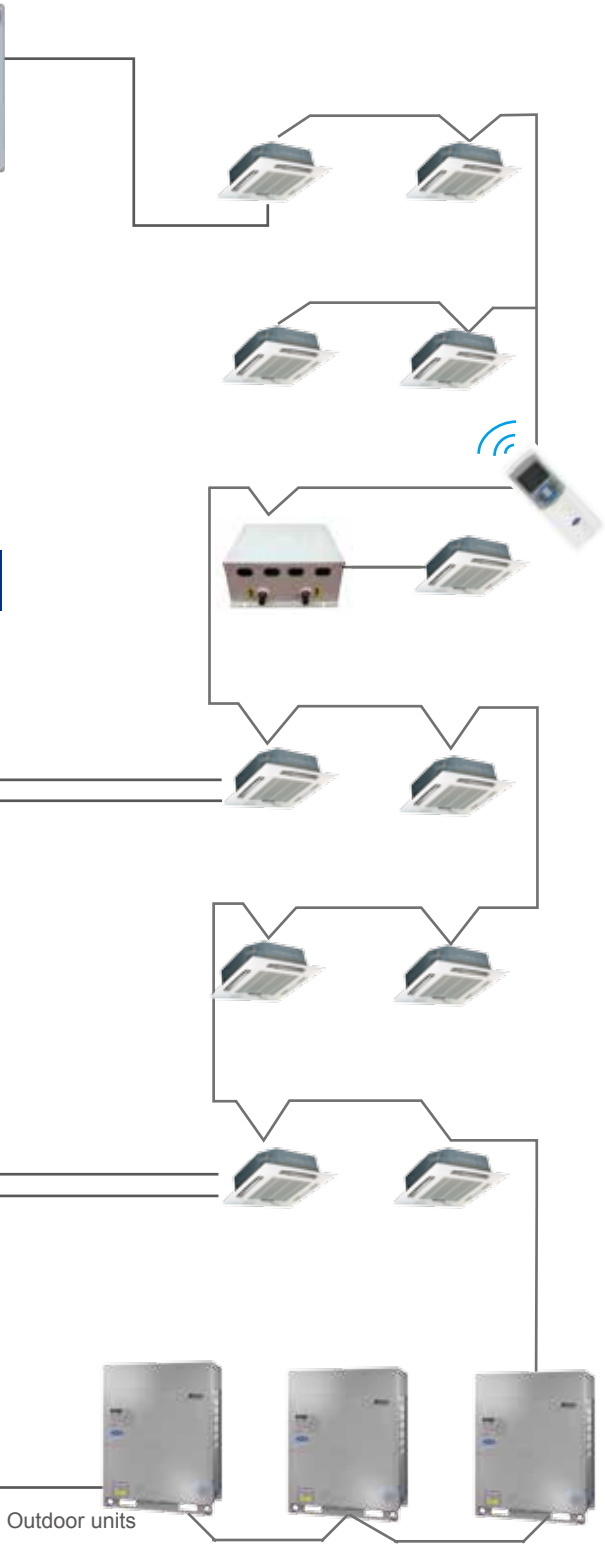

Comparison of Controllers

Item		Remote controller	Wired Controller			Centralized Controller	
Model name		WL-12-CM WL-14-CM	WR-12-CM	WR-120B-CM	WR-29B-CM WR-90D-CM	CRF-30-CM CRF-10-CM	WCRF-10-CM
MAX. controllable IDU			1	1	1	64	64
A/C control function	On/Off	●	●	●	●	●	●
	Operation mode setting	●	●	●	●	●	●
	Fan speed setting	●	●	●	●	●	●
	Room temp. setting	●	●	●	●	●	●
	Vertical swing	●	-	-	-	-	-
	Horizontal swing	●	●	●	●	●	●
	Air direction	●/-	-	-	-	-	-
	Economic mode	●	●	●	-	-	-
	Central setting	-	-	-	-	●	●
	Keyboard lock	●	●	●	●	●	●
	Mode lock	-	-	-	-	●	●
	Remote signal receiving	-	-	-	●	-	-
	26°C shortcut setting	-/●	-	-	-	-	-
Silent mode	-	-	●	●	-	-	
Display	Backlight	●	●	●	●	●	●
	Current time	●/-	-	●	-	-	●
	RC prohibition	-	-	-	-	●	●
	Address	-	-	-	-	●	●
	Error code	-	-	●	-	●	●
	Room temp.	-	-	-	-	●	●
Timer	Period	-	-	-	-	-	Week
	On/Off per day	-	-	-	-	-	4
	On/Off per week	-	-	-	-	-	28
	On/Off timer	●	●	●	●	●	●
Control	FOLLOW ME	-/●	●	-	●	-	-
	Emergent stop	-	-	-	-	●	-
	Emergent start	-	-	-	-	●	-
	Address setting	●	-	-	●	-	-
	BMS access	-	-	-	-	●	-
	Control via internet	-	-	-	-	●	-
	Air filter cleaning reminding	-	-	●	●	●/-	-

● : Available controller functions

- : Not available controller functions

Wireless Remote Controller



WL-14-CM



WL-12-CM

Functions

Portable device

The wireless remote controller is a portable control device that enables users to control the A/C anywhere within a distance of 11m.



Simplified user interface

Users can synchronize the air conditioners' parameters with the display panel on the wireless remote controller to precisely control a room's environment.

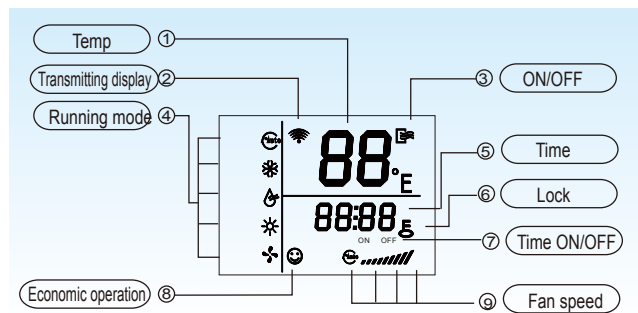

Background light

The background light allows users to operate the device in a dark room. The device lights up when a button is pressed, and turns off when a given operation is completed.

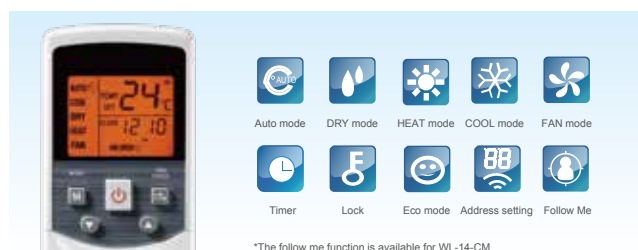

*The follow me function is available for WL-14-CM

Built-in timer

The built-in daily timer offers the convenience of automatically starting and stopping the system at set times.

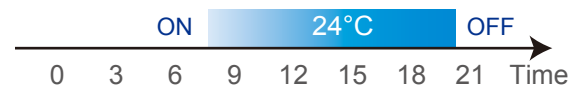

The indoor unit is set to work in automode from 8:00 to 20:00

Setting addresses

Besides the machine's auto addressing function, users can set the indoor unit's address on the wireless remote controller WL-12-CM/WL-14-CM.



Specifications

Model	WL-14-CM	WL-12-CM
Dimensions (H×W×D)(mm)	150×60×15	150×65×20
Power (V)	1.5V(LR03/AAA)×2	

Wired Controller



WR-29B-CM



WR-90D-CM

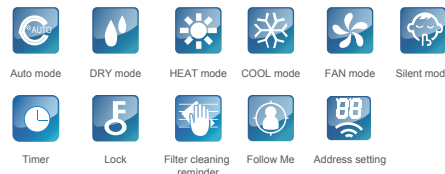

Functions

Air filter cleaning reminding

The wired controller records the total running time of the indoor unit. When the accumulated running time reaches the pre-set value, it will remind users need to clean the air filter of the indoor unit.

Clean the filter regularly can keep indoor air fresh and clean, good for your health.

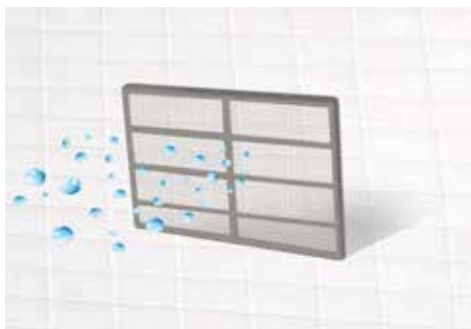

*Available for WR-29B-CM / WR-90D-CM model.

Silent mode

Under the cooling, heating and auto mode, when operate the silent mode, it can reduce the running noise through setting the fan speed to low. This will help you bring a quieter environment.

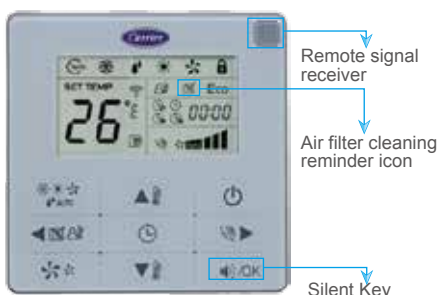

WR-29B-CM
(Touch key)

Remote signal receiving function

WR-29B-CM and WR-90D-CM provide a signal receiver for remote controller. Signal from remote controller can be received by a wired controller, then sent to the indoor unit and it conveniences to control.

Locking wired controller

The locking function can be used to prevent other people from using the controller.

Specifications

Model	WR-29B-CM	WR-90D-CM
Dimensions (H×W×D)(mm)	120×120×20	86×86×16.5
Power (V)	DC 5V	

Wired Controller



WR-12-CM



Functions

Follow me

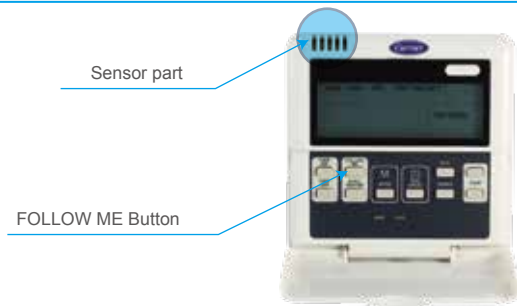

With the FOLLOW ME function, the wired controller can detect the air temperature at the user's altitude instead that of the ceiling or floor. This helps making the room environment comfortable and the temperature accurate.

*The follow me function is available for WR-12-CM/WR-29B-CM model.

Setting addresses

With the address setting function, and easy for the installation and future service. The service person can set the address for indoor unit by, WR-29B-CM and WR-90D-CM.

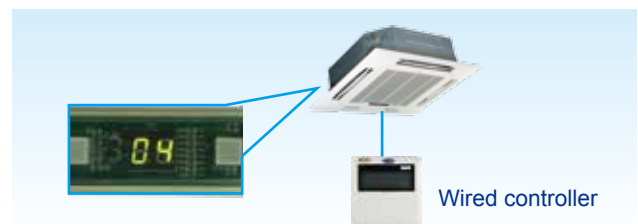

Built-in timer

Built-in daily timer offers the convenience of automatically starting and stopping the system at set times.

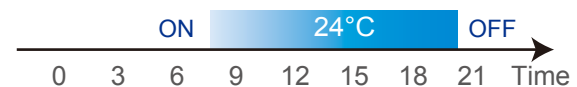

The indoor unit is set to work in automode from 8:00 to 20:00

Easy connection

The wired controller conveniently connects to the indoor unit's display panel via connecting wire.

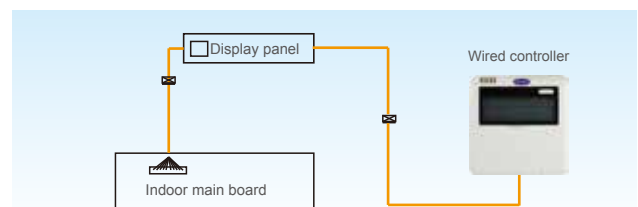

Specifications

Model	WR-12-CM
Dimensions (H×W×D)(mm)	120×120×15
Power (V)	DC 5V

Centralized Controller

Indoor Centralized Controller



CRF-10-CM



CRF-30-CM

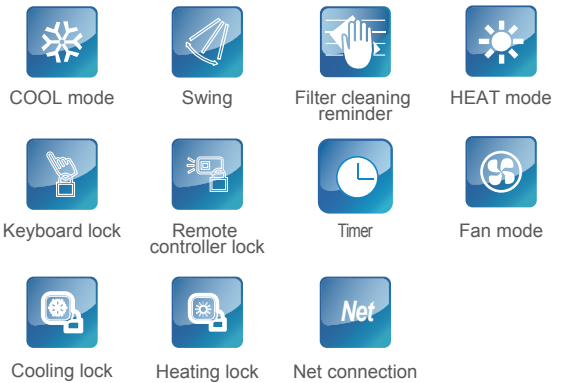

Functions

Centralized control

The centralized controller is a multifunctional device that can control up to 64 indoor units within a maximum connection length of 1,200m.

The device connects to the master outdoor units of Carrier's newly designed products to simplify and centralize the wiring configuration. The two connection modes are as follows:

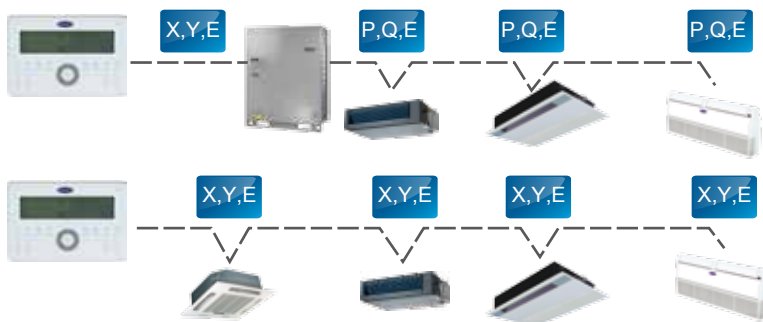

Three lock modes

Centralized controller provides a superior way to manage the indoor units. Users are able to make their own choice from locking the wireless controller, locking the running mode or lock the centralized controller's keyboard as they wish.

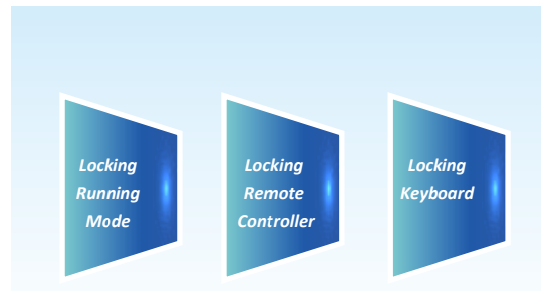

Indoor unit working status display

The centralized controller displays indoor units' working status and error codes so users can easily identify faults via checking the error codes table in the user's manual before contacting a service engineer.

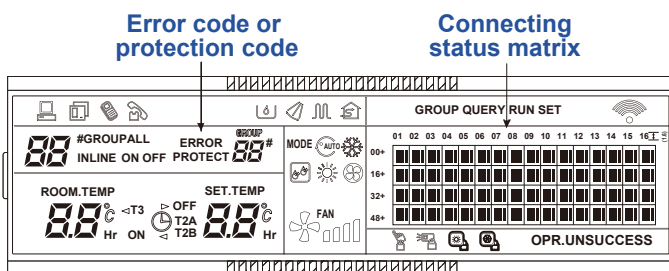

Air filter cleaning reminder function

The air filter cleaning reminder function is only available on the touch-key central controller CRF-30-CM. The "FL" icon indicates that the air filter in a given indoor unit needs cleaning.

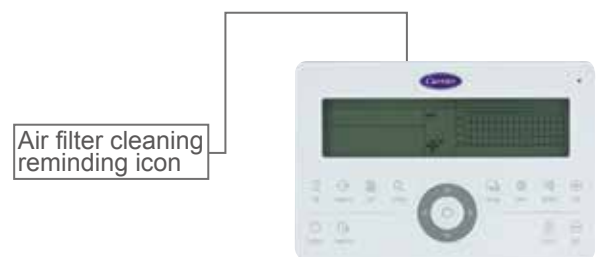

CRF-30-CM

Functions

Stylish design

CRF's stylish design suits high-end environments. The keyboard lock function is used to prevent operational mistakes.



Single/unified control

The control object can be either a single unit or all units, which vastly simplifies the control process. Operation signal feedback ensures that all units are working in the correct mode.

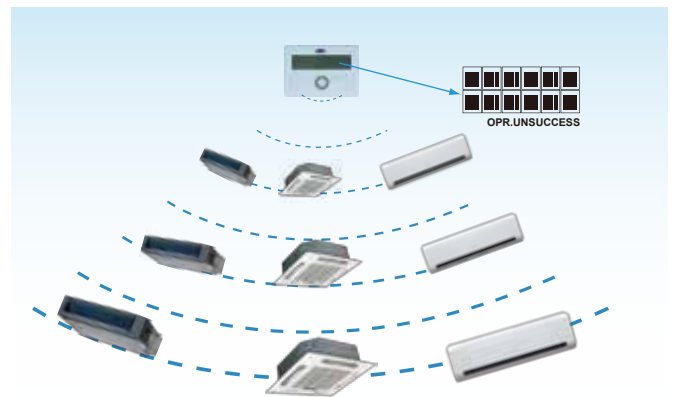

Easy installation

Centralized controller offers two different appearances to mostly suit the installation. The A structure must be embedded into the wall and the B structure doesn't need. Both of them are easy to operate.

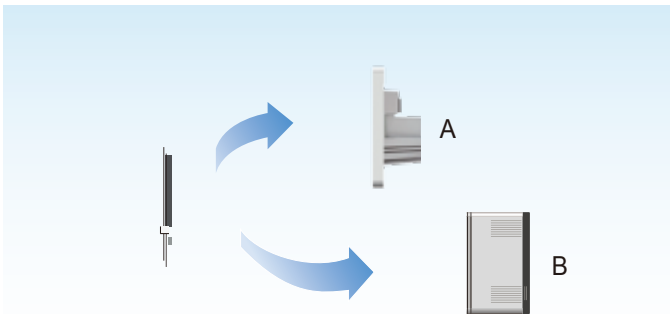

*The A,B structure is available for CRF-30-CM, and CRF-10-CM only has B structure

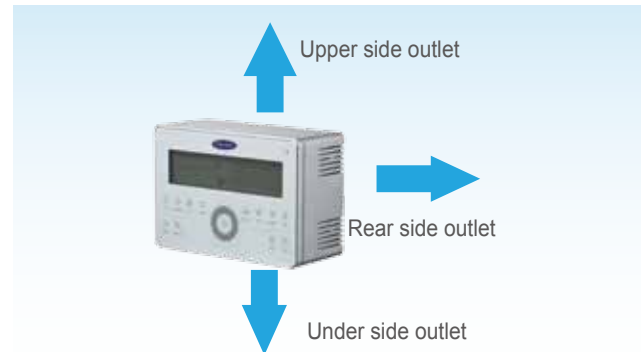

B structure leading-out mode sketch

Access to network monitoring

The centralized controller is able to bridge up to 64 indoor units on the network monitoring and building management systems.

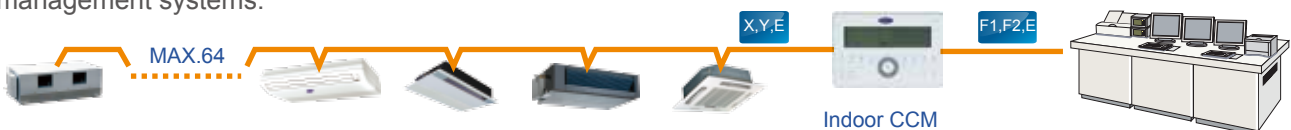

Specifications

Model	CRF-10-CM	CRF-30-CM
Dimensions (H*W*D)(mm)	179×119×74	180×122×78 and 180×122×68
Power (V)	198-242V(50/60Hz)	

Centralized Controller

Weekly Schedule Centralized Controller

WCRF-10-CM

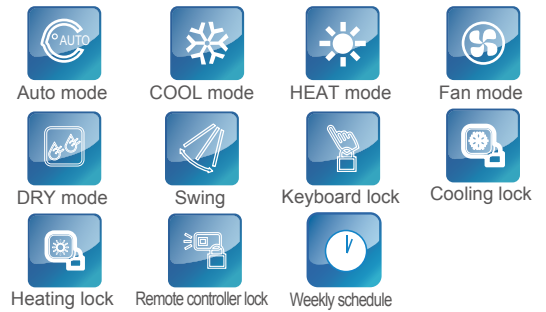

Functions

Weekly schedule

WCRF-10-CM can include up to 64 indoor units in the weekly schedule. Users can set up to 4 periods per day, and select the desired running mode and room temperature. The operating object can be a single indoor unit or all the indoor units.

	8:00	16:00	23:59
Sun	28°C	22°C	24°C
Mon	26°C	22°C	17°C
Tue	26°C	22°C	17°C
Wed	26°C	22°C	17°C
Thu	26°C	22°C	26°C
Fri	26°C	22°C	26°C
Sat	28°C	off	24°C

Three lock modes

Centralized controller WCRF-10-CM provides a superior way to manage the indoor units. Users are able to make their own choice from locking the wireless controller, locking the running mode or lock the WCRF-10-CM's keyboard as they wish.

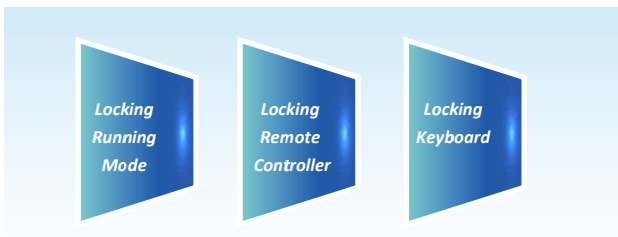

Single/unified control mode

The control object can be either a single unit or all units, which vastly simplifies the control process. Operation signal feedback ensures that all units are working in the correct mode.

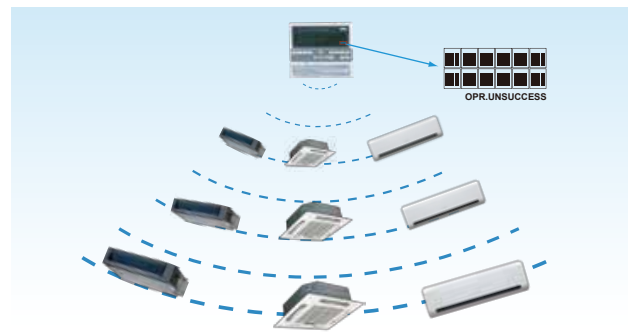

Indoor unit working status display

WCRF-10-CM displays indoor units' working status and error codes so users can easily identify faults via checking the error codes table in the user's manual before contacting a service engineer.

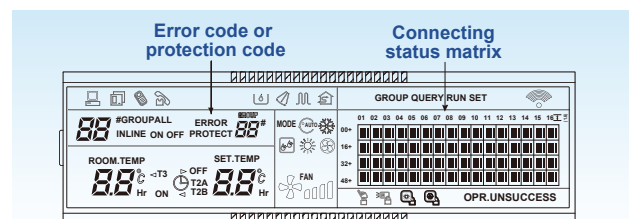

Specifications

Model	WCRF-10-CM
Dimensions (H*W*D)(mm)	179×119×74
Power (V)	198-242V(50/60Hz)

Centralized Controller

Unified On/Off Controller

CRF-90-CM

Unified controller design with graceful appearance and explicit panel.



Functions

Unified control

CRF-90-CM offers on/off and heating/cooling functionality for indoor units based on preset temperatures to ensure easy management.



Centralized control

CRF-90-CM can be used to centrally control up to 16 indoor units.

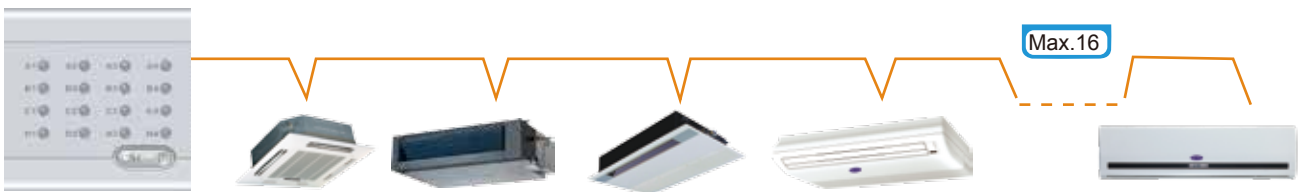

Light indicator

The LEDs on CRF-90-CM indicate the indoor units' running status for easy fault detection. The lights switch off automatically to save energy once a given operation is complete. The indicators are as follows:

Light	Blue	Red	Flash
Single On/Off key	Cooling/Fan	Heating	IDU Error
Unified On/Off key			EEPROM Error

Easy installation

CRF-90-CM can be easily mounted on the built-in cabinet:

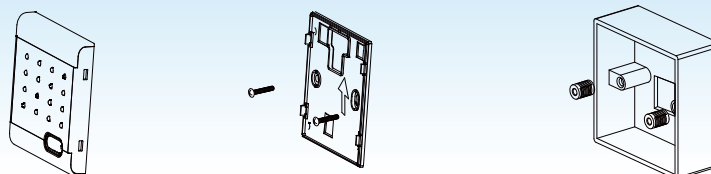

Specifications

Model	CRF-90-CM
Dimensions (H*W*D)(mm)	90×86×8
Power (V)	DC 5V

Centralized Monitor

Outdoor Centralized Monitor

CRC-10-CM



Query parameters



4-way/EXV valve



Protection/Error codes



Power consumption



With the ODU communication



With the PC communication



Forced Cooling

Functions

ODU parameters display

CRC-10-CM enables users to easily check outdoor units' running status, including frequency, temperature, current, pressure, protection codes and error codes.

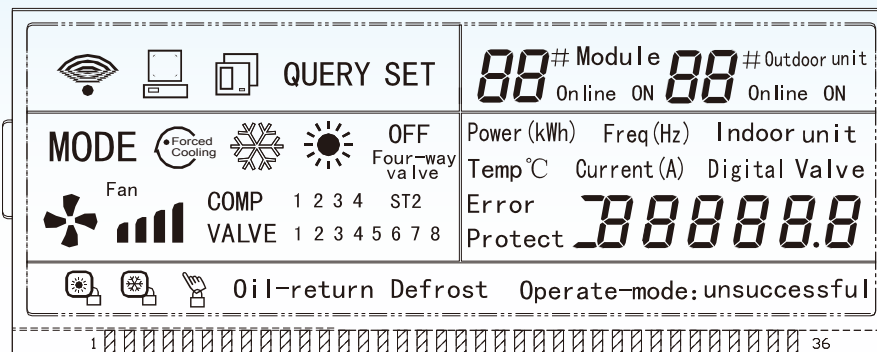

Graph 2 LCD Screen

Access to network monitoring

CRC-10-CM can connect up to 8 refrigerant systems and 32 outdoor units to the network system.

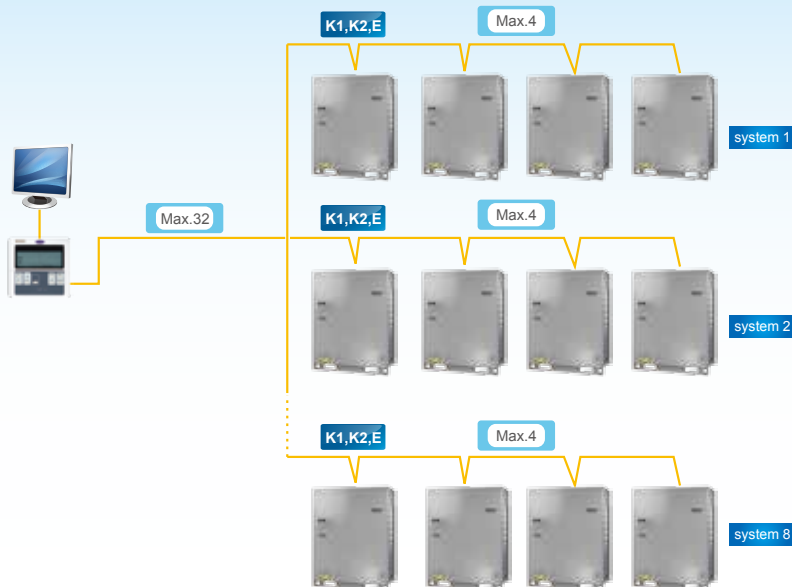

Specifications

Model	CRC-10-CM
Dimensions(H×W×D)(mm)	120×120×15
Power (V)	198-242V(50/60Hz)

Central Control Software



Various Managements



Simple Operation and Management

Click & Operate, a user-friendly interface allows even non-experts to perform the building management system easily.

Data Management

Operational information of individual indoor units are monitored, allowing for distribution of power consumption at outdoor units.

Stores operation data on multiple systems and displays it in graphical format for visual management.

Uses IMM software to generate tenant reports and help building owners bill for energy use.

Electricity Charge Distribution(Patented)

Provides information on proportional electrical power distribution to optimize electricity consumption management.

Uses software to calculate electric power proportional distribution, output and save electricity consumption data for each indoor unit (or group) which is connected to the intelligent manager.

Applies the patented Carrier Calculation Method to calculate consumption rates according to capacity demand which is based on various parameters: setting temperature, room temperature, running mode, rated HP, public areas, unused rooms, and nighttime use; outputs this information on a charge calculation sheet to evenly divide power consumption charges among tenants.

Highlights



Web Access function

With the web access function, a PC, laptop computer or a smart phone can be used as a remote controller.



Visual Navigation

Clicking the jump button will display a list of all available screens. Clicking the back button will return to the previous screen.



Energy Saving Management

Based on a predetermined schedule, the Intelligent Manager executes capacity control and intermittent operations on all air conditioning units to maintain a high comfort index.



Data Backup

The M-interface will automatically back up data on the installed SD card (2GB) in case system failure occurs, such as: power failure or system dam. IMM software also stores the previous 3 months' operational data on the HDD.



Schedule Control

Automatically performs facility start/stop control, switches the operating mode, sets temperatures and enables/disables the remote control according to the present time schedule. 4 sections and 20 actions per day for each single unit or group.



Multiple Languages

Provides seven language settings:

English	French	Italian
Russian	German	Spanish
Simple Chinese		



Warning Message

The system can receive error messages from air conditioning units in more than one buildings or structures via public phone lines.

*Requires the Carrier "SMS Modem" to send automatic warning messages to designated phone numbers.



Electricity Charge Distribution

Electricity charges can be easily divided when billing users for air conditioning power charges; for example, for tenants in a commercial building, offices in a rented building, or rooms in a hotel.

Accessories

Data converter

CIF-15-CM

- Can realize data conversion between TCP/IP protocol and 485 protocol.
- WEB function realizes VRF system's webpage access.
- User can monitor and query the air conditioners through LAN and WAN.
- Providing the TCP / IP port for VRF system of Carrier to achieve WEB/HTTP/TCP/IP access.
- Can remotely control the A/C systems through computer, iPhone, iPad or other intelligent terminals.



Network example

- Can be directly connected with XYE port of the indoor units.
- Up to connect 64 indoor units.
- CRF-10-CM/CRF-30-CM is optional and can be connected with CIF-15-CM through F1, F2 and E ports.
- The system consisting A/C system, data converter CIF-15-CM, router, cloud server and control terminal.

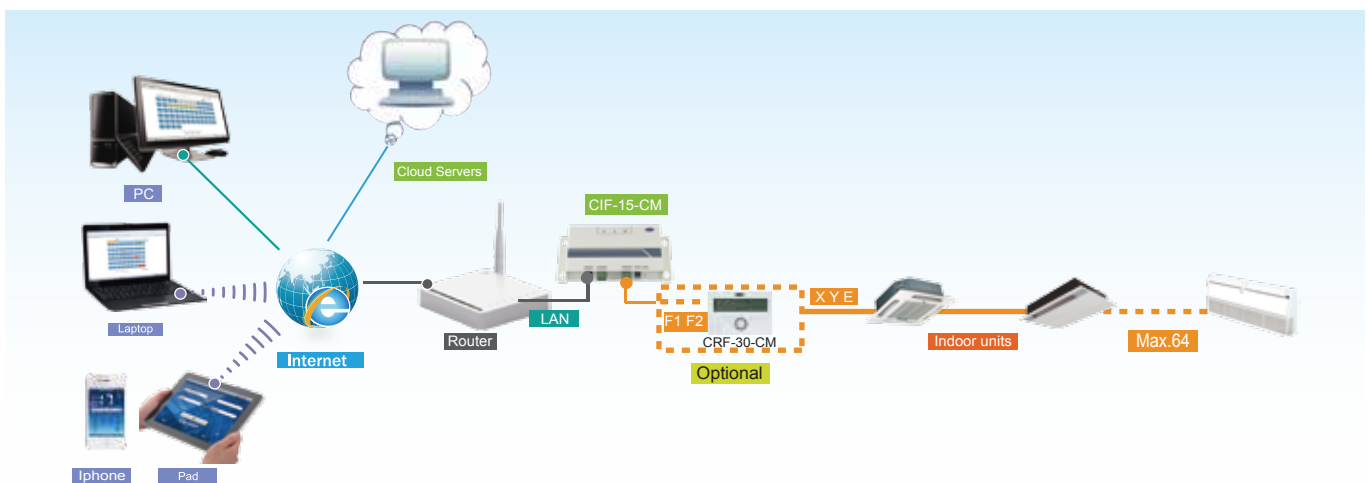

Simply control interface

- Software control/ Cloud server control (WEB access).
- Click & operate, a user-friendly interface.
- Allows signal and group control.
- Simplified user control interface.
- Color indication and icon makes it easy to recognize unit state.
- Full screen display and the temperature can be adjusted by fingers' sliding.



Weekly schedule control

- With weekly schedule function for iPad.
- Multiple sections in each day for single unit or group.
- Automatically performs facility start/stop control, operating mode, setting temperatures and according to the present time schedule.



Web features

- Query and control single unit or group.
- Weekly schedule setting: can set multiple sections in each day for single unit or group.
- Group user control : a user can use the same ID to manage hundreds of CIF-15-CM, when selecting the "As group user" button on the login page.
- History error: easy service and management with history error function.

Intelligent control

- The air conditioner remote control can be accessed by mobile phone or tablet computer.
- You can query the running state of the air conditioner any time and any where and even make an appointment in advance.
- Can remotely turn off the air conditioner to avoid the power waste, when you are in a hurry to leave.



Accessories

BACnet® BMS Gateway NW-BCN-CM

Contains 4 groups of RS485 communication ports and be able to connect up to 256 indoor units or 128 outdoor units to the BMS. Be free to connect to the BMS or not.



Network example

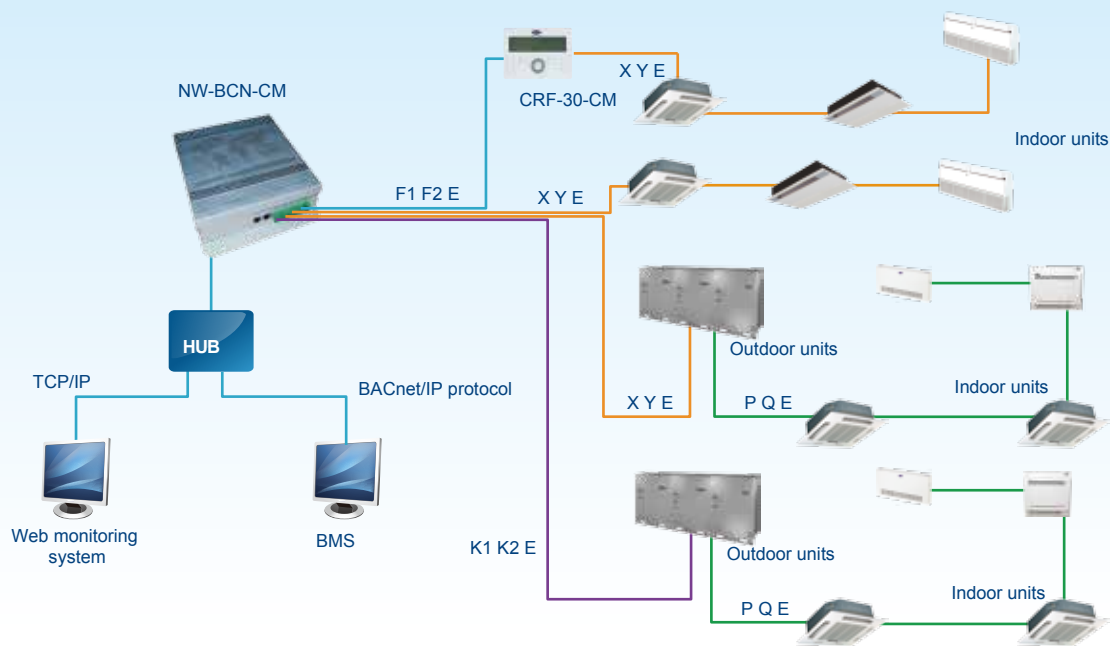

Monitoring units online

NW-BCN-CM allows users to track units' operational status and change their running parameters on Internet Explorer for maximum control convenience

Wide compatibility

NW-BCN-CM has a wonderful adaptability to the BMS

	Company	BMS software	Brand
1	SIMENS	APOGEE	
2	TRANE	Tracer Summit	
3	Honeywell	Alerton	
4	Schneider	Andover	
5	Johnson	METASYS	

Accessories

Modbus BMS Gateway

CRF-18-CM/CRF-18U-CM

Supports Modbus protocol networks

Bridges the Carrier central A/C system and the BMS

Establishes a Modbus network comprising up to 1,024 indoor units and 64 outdoor units

Transfers data in RTU mode

Provides a wide voltage range: 12-48V DC



Network example

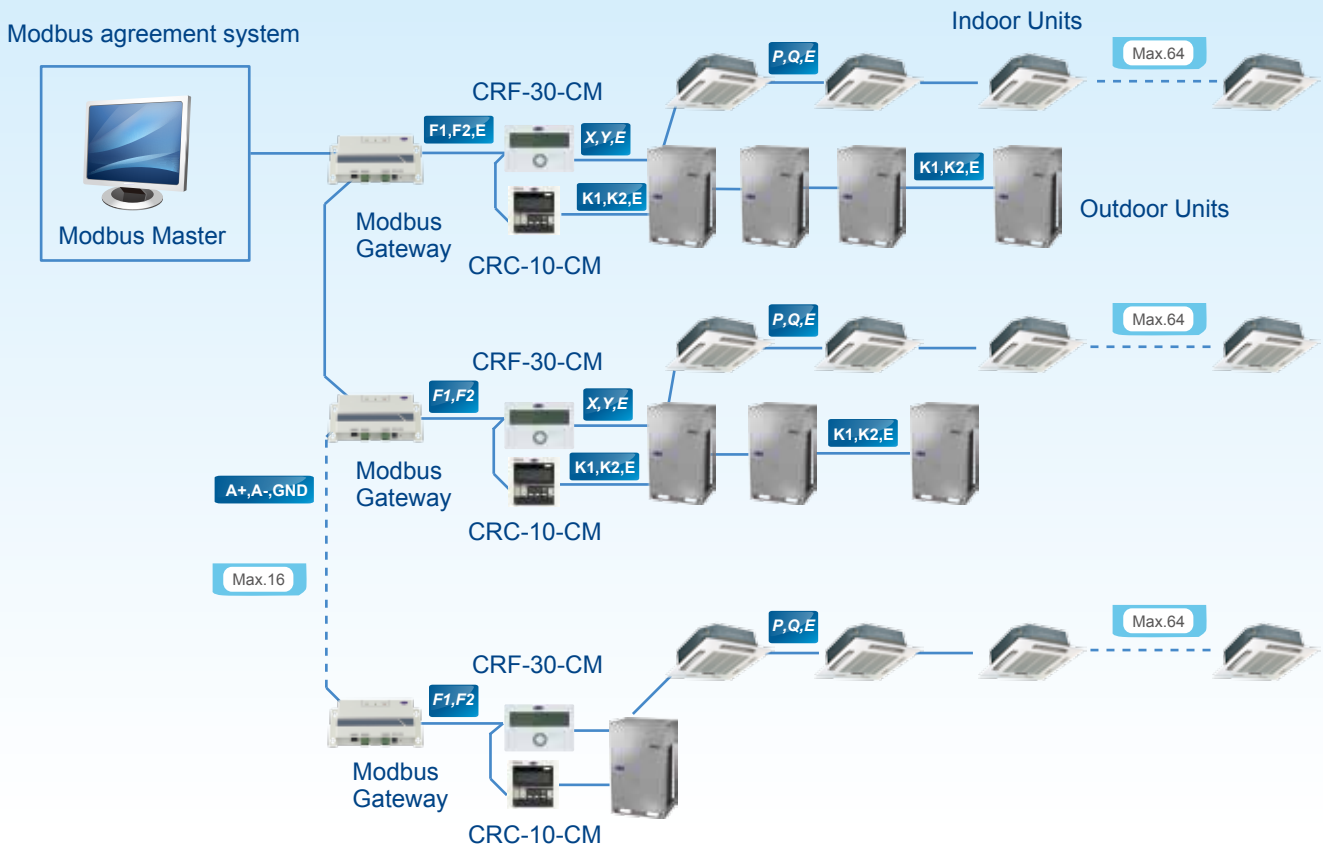

One Modbus gateway can bridge one refrigerant system with a PC or the Modbus master.

Config A/C System via Web

When the Modbus network is set, users can conveniently configure their A/C network system over the Internet using different TCP/IP browsers.



Dimensions

The Modbus Gateway is designed with a small size. It's equipped with an installation track for the easy on-site installation.

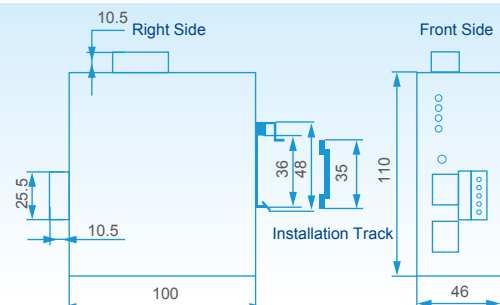

Accessories

LonWorks® BMS Gateway NW-LNW-CM

Compliance with LonMark protocol, and realizes the management and control of A/C.

Can connect up to 64 indoor units to the BMS.

Realizes non-polarity communication, and also the application can be download online.



Network example

Connection method 1: Suitable for all of air conditioner systems and connect max.64 indoor units.

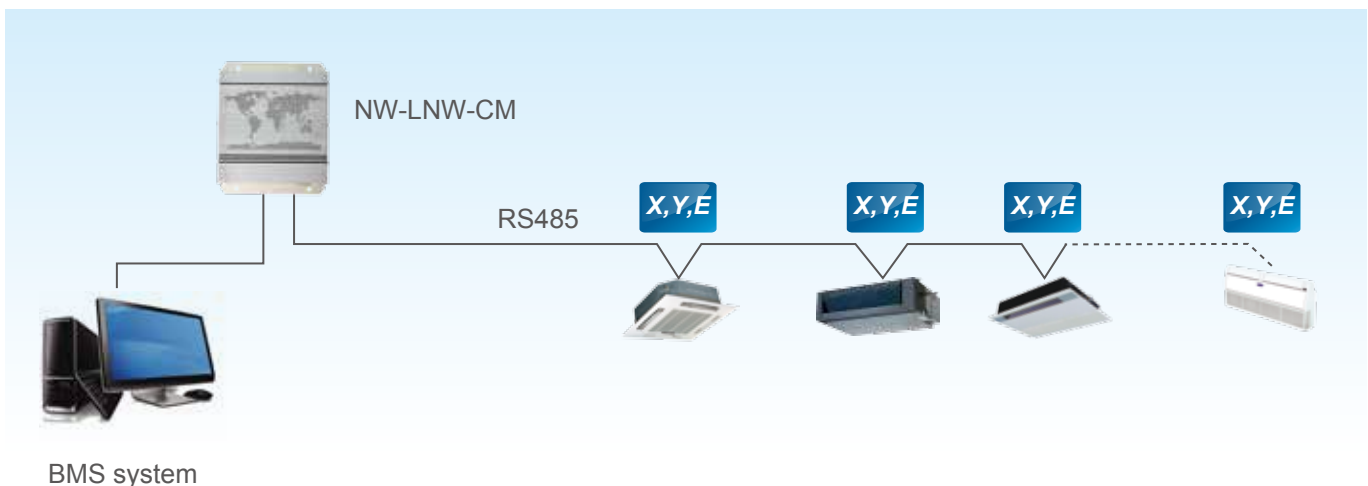

Connection method 2: Only suitable for X-power standard system and connect max.64 indoor units.

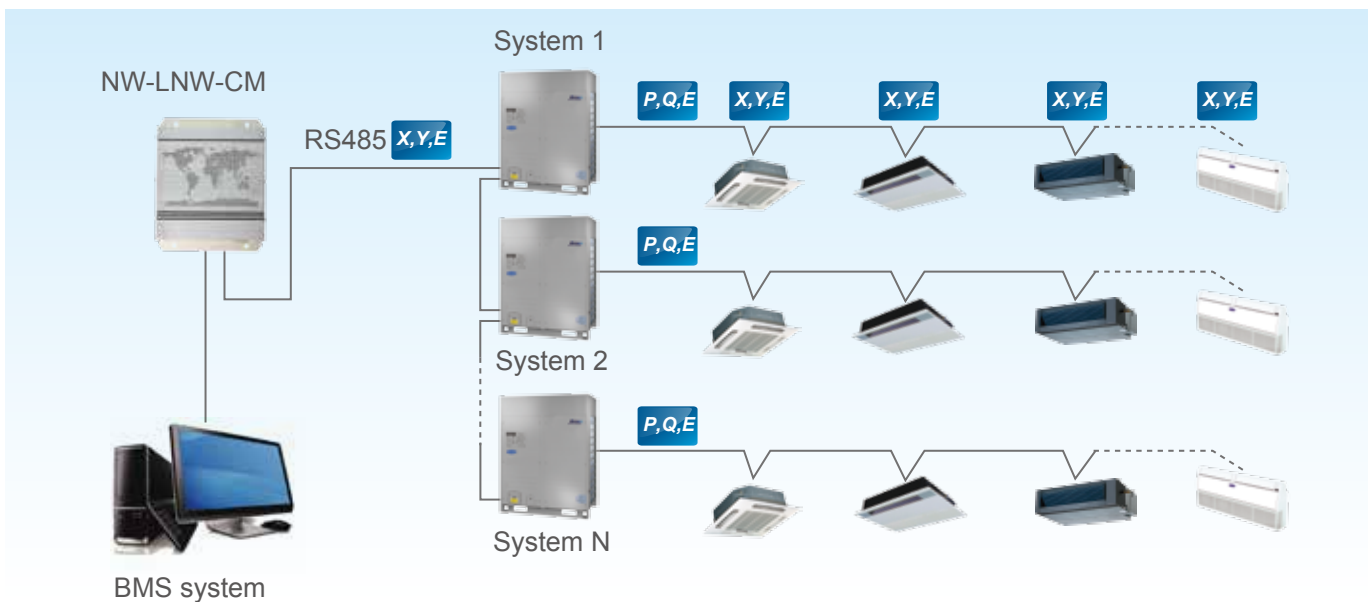

Specifications

Model	NW-LNW-CM
Dimensions (H*W*D)(mm)	319×251×61
Power (V)	177~265V AC(50Hz/60Hz)

Accessories

3-Phase Protector

HWUA/DPB71CM48

Detect the power condition and make the corresponding protecting action.

Protect the compressor from being damaged.

Automatically distinguish the abnormal power supply conditions and automatically recover.



HWUA DPB71CM48

Excellent reliability

The protector protects the entire system from power supply problems, and auto restart after recovery.

Specifications

Model	With over/under voltage function				Without over/under voltage function
	HWUA	DPA53CM23	HWUA	DPB71CM48	DPA51CM44
Power supply (V-N-Hz)	220~480V-3N 50/60Hz	208~480V-3N 50/60Hz	220~480V-3N 50/60Hz	380~480V-3N 50/60Hz	208~480V-3N 50/60Hz
Temp. range(°C)	-20°C~50°C	50Hz: -20°C~60°C 60Hz: -20°C~50°C	-20°C~50°C	-20°C~50°C	50Hz: -20°C~60°C 60Hz: -20°C~50°C
Rated operational power(VA)	2.9 VA	7 VA	2.9 VA	13 VA	13 VA
Over voltage	12%	12%	18%	18%	/
Under voltage	-12%	-12%	-12%	-12%	
Phase imbalance	8%	/	8%	8%	
Dimensions(W×H×D)(mm)	90×69×35	81×67.2×17.5	90×69×35	81×67×35	81×67.2×17.5

Digital Power Ammeter

DTS634/DTS636

Calculates power consumption.

Does not need adjusting after long-term use.

Corresponds one outdoor unit to one digital power meter.



Low power consumption

The digital power meter consumes minimal energy.

Voltage circuit: less than 2W/10VA

Current circuit: less than 2.5VA

Indications and installation

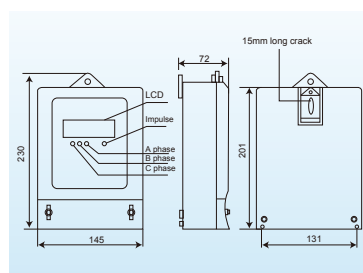

The digital power meter is tested after manufacture so it can be immediately deployment and used on-site. The LED indicators and installation schematic are shown in the figure on the left.

Specifications

Model	DTS634/DTS636
Dimensions (H*W*D)(mm)	230×145×72
Power (V)	200V-500V(50/60Hz)

Remote Alarm Controller

WR-32-CM



Functions

Simple design

WR-32-CM is specially designed for engineering applications. It does not display the ODU's working parameters, but it can connect to the alarm device when ODU is working abnormally, the RUN light will flash.

Specifications

Model	WR-32-CM
Dimensions (H*W*D)(mm)	150×85×70
Power (V)	198-242V(50/60Hz)

Indoor Unit Group Controller

WR-150A-CM



Functions

Simple design

WR-150A-CM is specially designed for X-power indoor units. A group controller can connect up to 16 X-power indoor units through X1, Y1 and E terminals, but it cannot directly connect to the central controller. If you need to use a central controller or a PC, you can connect to the XYE from an outdoor unit. A group controller can control a group of indoor units simultaneously, and query the running status of each unit in the group via the display panel.

System wiring diagram

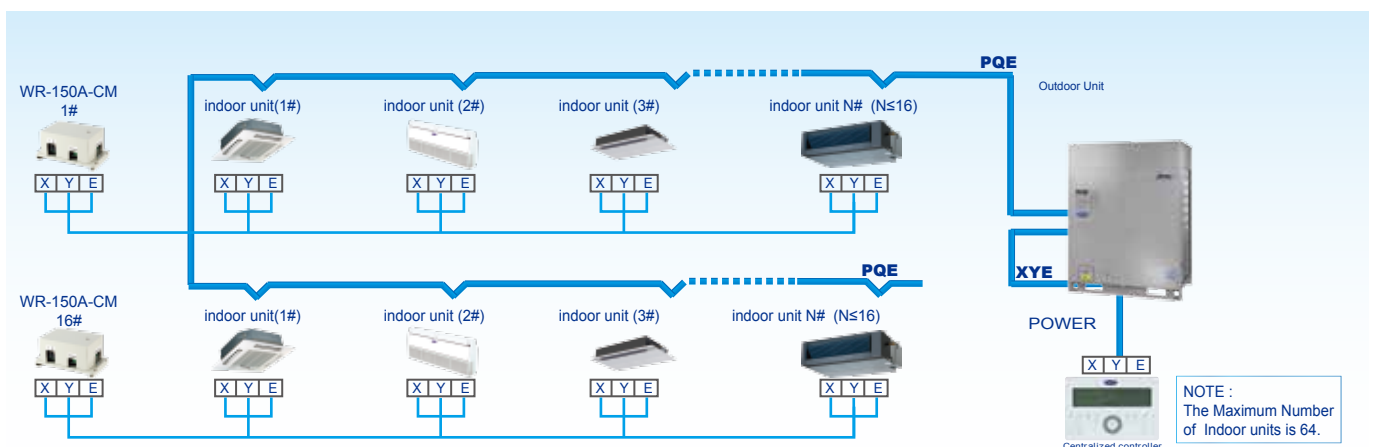

Specifications

Model	WR-150A-CM
Dimensions (H*W*D)(mm)	150×85×70
Power (V)	198-242V(50/60Hz)

Accessories

Infrared sensor controller

CA-NIM09

Automatically adjust the room environment.

Automatically extend the shutting down time, avoiding frequent ON/OFF.

Graceful appearance accommodates itself to different buildings.



Installation example

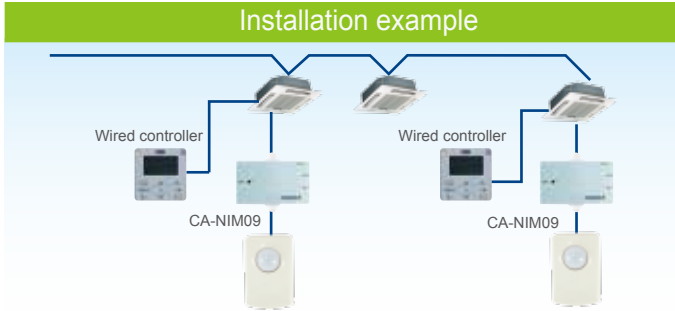

Remote controller or wired controller can control indoor unit.

Electrical wiring

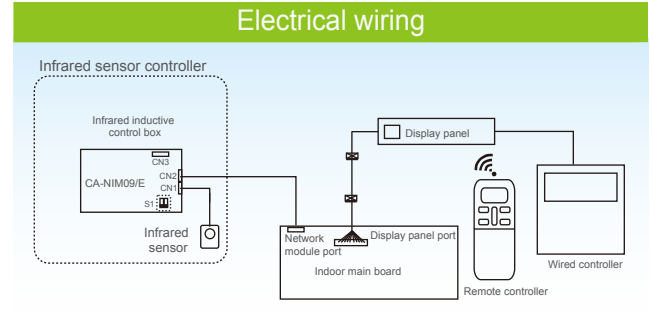

Specifications

Model	CA-NIM09
Dimensions(H×W×D)(mm)	Sensor part: 46×30×25.6, Control box: 86×72.8×15.5
Power	DC 5V

Hotel Card Key Interface Module

CA-NIM05

Cooperate with the wired controller to automate control.

Eliminates the need for high voltage power, making the device safe and steady.

Includes a build-in auto-restart function.

Remote controller or wired controller can control indoor unit.



Installation example

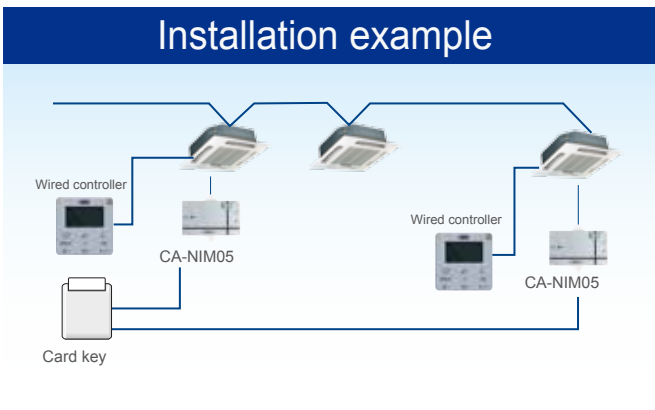

Electrical wiring

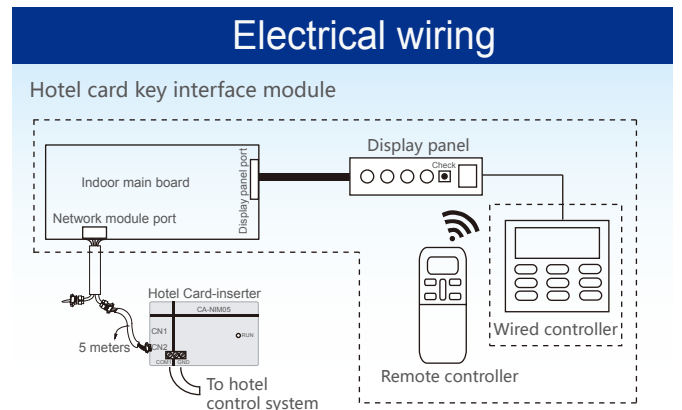

Specifications

Model	CA-NIM05
Dimensions (H*W*D)(mm)	86×72.8×15.5
Power (V)	DC 5V

Accessories

AHU Control Box

AHUKZ-01B/AHUKZ-02B/AHUKZ-03B

X-Power Standard functions inside.

Can be used to connect VRF outdoor units with DX AHU or other brand indoor units



Introduction

AHUKZ-01B/AHUKZ-02B/AHUKZ-03B is an independent control box that can connect a AHU to X-Power system to realize centralized control with X-Power system. Control box wiring is as follows:

Maximum 4 AHU Control Box can be parallel installed to one 3rd party indoor unit.

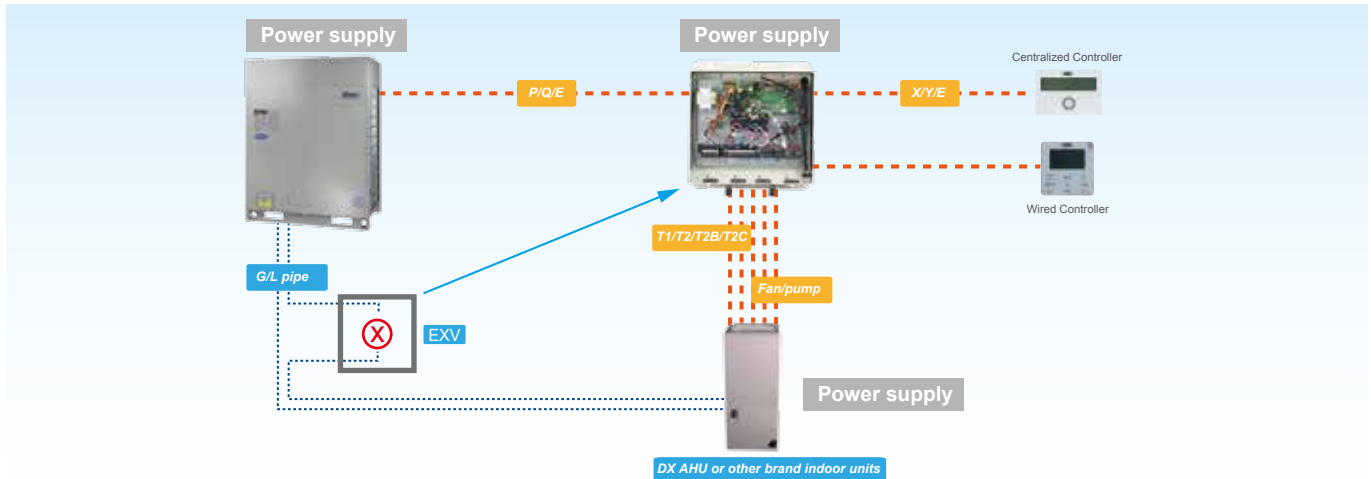

Selection software

To meet consultants' and distributors' requirements, Carrier has developed an advanced design automation tool that can be used in AutoCAD-based CAD version or Windows-based Sales version. The software provides quick and convenient selectable options for users, supports multiple languages, and greatly improves the selection process.

Windows Version

- Load calculation: Provides two calculation methods (detailed room load calculation and rough load calculation).
- Indoor & outdoor units selection: There are versatile indoor units and different outdoor units for choosing.
- Piping drawing: Displays the detailed layout of an A/C system and the parameters for piping and branch distributors.
- Controller selection: Provides a selection of controllers for indoor units and outdoor units, including wireless and remote controllers for indoor units.
- Report output: Outputs a comprehensive selection report as a Word or PDF document.

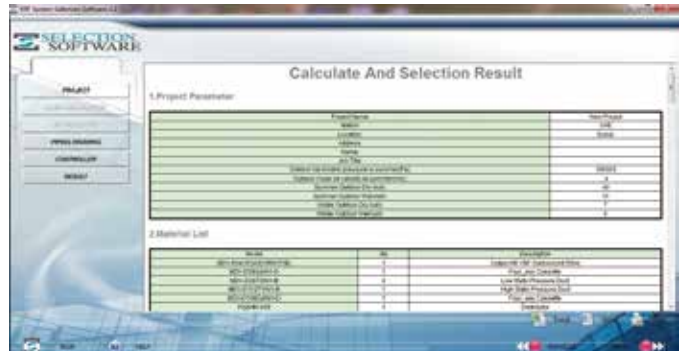
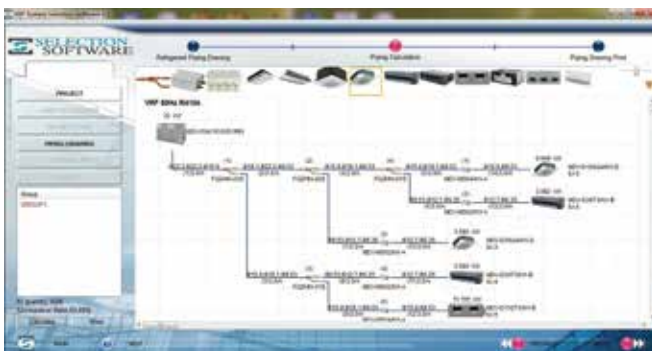

CAD Version

AutoCAD add-on software

Automatic Calculation: Refrigerant & drain pipe size

Automatic Selection: Distributor kit & branch joint

System Check: Installation regulation & refrigerant addition

Automatic Report: Piping installation diagram, equipment list & quotation

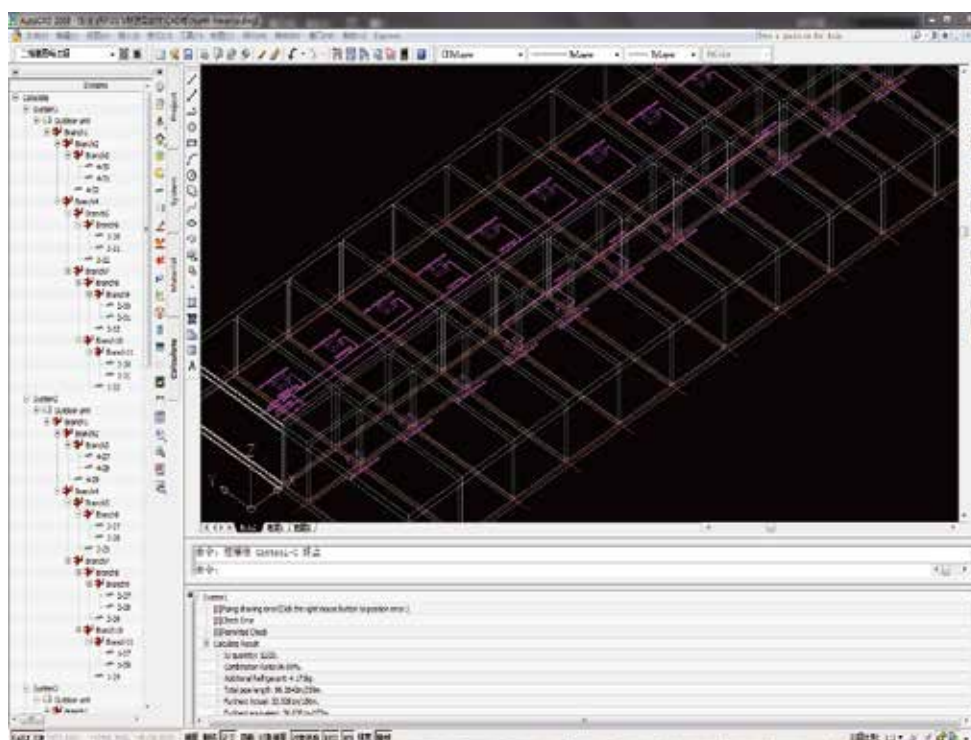
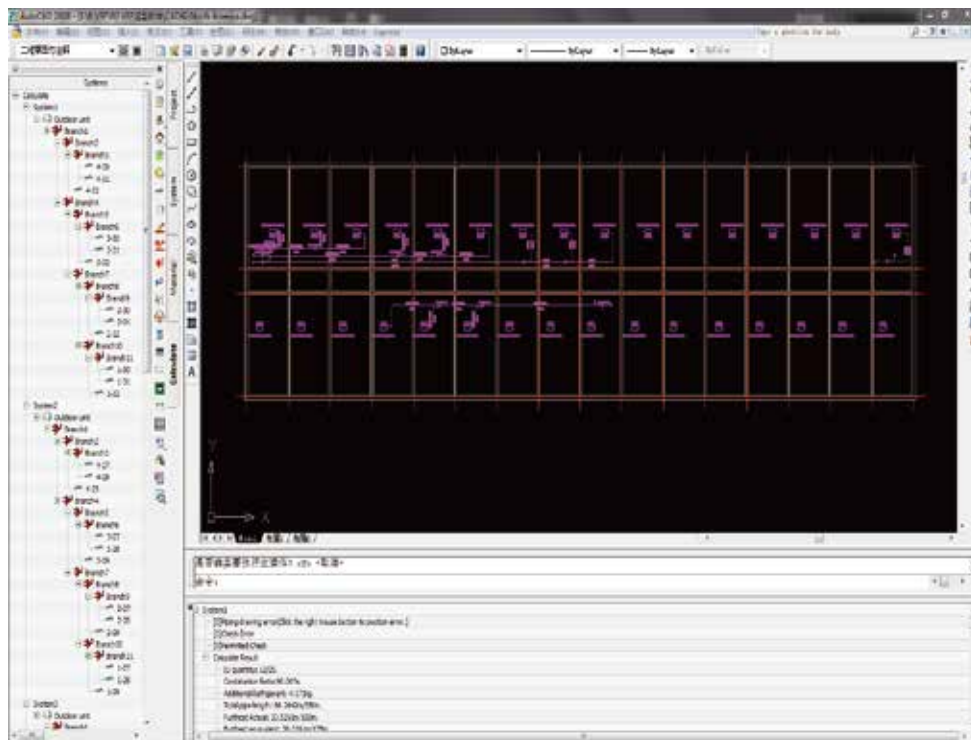

Branch Pipe >>



Branch Pipe

Branch joints of two-pipe refrigerant system

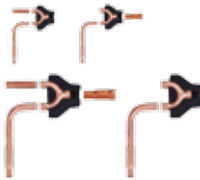
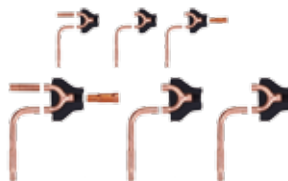
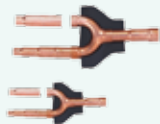
Model	Appearance	Model name	Packing Size (mm)	Gross Weight (kg)	Description
Branch joint for R410A outdoor unit		BJC-02-CM(i)	255×150×185	1.5	For two outdoor units connection
		BJC-03-CM(i)	345×160×285	3.4	For three outdoor units connection
		BJC-04-CM(i)	475×165×300	4.8	For four outdoor units connection
Branch joint for R410A indoor unit		BJF-224-CM(i)	90×105×100	0.4	A* < 16.6kW
		BJF-330-CM(i)	290×105×100	0.6	16.6 ≤ A* < 33kW
		BJF-710-CM(i)	310×130×125	0.9	33kW ≤ A* < 66kW
		BJF-1344-CM(i)	350×180×170	1.5	66kW ≤ A* < 92kW
		BJF-E1344-CM(i)	365×195×215	1.9	92kW ≤ A*

A*:The total capacity of indoor units which is connected to this branch joint



Carrier InterAmerica Corporation (CIAC)
10801 NW 103rd Street Suite 1, Miami, FL 33178
www.carriercca.com
Carrier X-power VRF 2015
Cat-v.01